

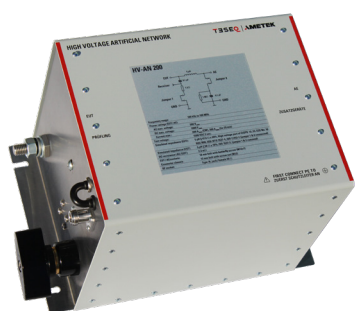

HV-AN 200 HIGH VOLTAGE ARTIFICIAL NETWORK



- 5 μ H AN/LISN as defined in
- High voltage part of CISPR 12 (draft), CISPR 25, ECE No. 10 R05/R06, ISO 11452-1 and ISO/DTS 7637-4
- ISO 7637-2

The artificial network HV-AN 200 offers a solution for high current and high voltage connections to the EUTs. The AN is used to simulate the impedance of a vehicle harness to determine the behavior of EUT and meet the requirements of ISO 7637-2 and the HV part of CISPR 12 (draft), CISPR 25, ECE No. 10 R05/06, ISO 11452-1 and ISO/DTS 7637-4.

Technical specifications

Frequency range:	100 kHz to 100 MHz
Power ratings (EUT/AE)	
AC max. voltage:	500 V _{RMS}
DC max. voltage:	1000 V _{RMS}
Current max.:	200 A _{RMS} (CW), 300 A _{RMS} (for 20 min)
Test voltage:	1500 VDC 2 sec.
Simulated impedance (EUT):	5 μ H 47.6 Ω \pm 20%, High voltage part of CISPR 12, 25, ECE No. 10 R05/R06, ISO/DTS 7637-4, ISO 11452-1 (jumper 1 & 2 connected)
Simulated impedance (EUT)	5 μ H 50 Ω \pm 10%, ISO 7637-2 (jumper 1 & 2 removed)
DC resistance (AE/EUT):	2.3 m Ω
EUT/AE sockets:	12 mm bolt with butterfly screw (M12x1)
Connector chassis	12 mm bolt with screw nut (M12)
RF socket:	Type-N, jack/ female 50 Ω

Mechanical specifications

Size (L X W x D):	365 mm x 203 mm x 203 mm
Weight:	approx. 7.2 kg

Environmental conditions

Classification	Indoor use only
Operating temperature	0 °C to +30 °C
Storage temperature	-10 °C to +60 °C
Relative humidity	up to 90 % (no moisture condensation)

HV-AN 200 HIGH VOLTAGE ARTIFICIAL NETWORK



HV-AN 200, view to the EUT port



HV-AN 200, view to the AE port

Example of HV-AN 200 schematic

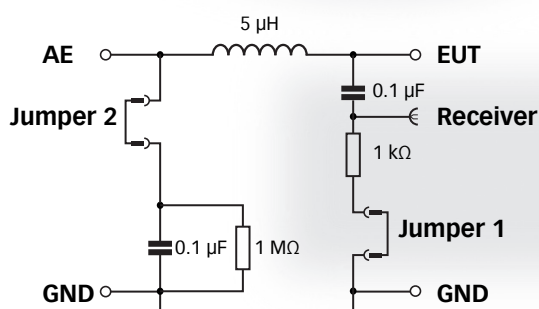

Standard	Jumper 1	Jumper 2
High voltage part of CISPR 25, CISPR 12, ECE No. 10 R05/R06, ISO 11452-1, ISO/DTS 7637-4	●	●
ISO 7637-2	○	○

“●” jumper used, connected, “○” no jumper, not connected

AMETEK CTS Europe GmbH
Landsberger Str. 255 · 12623 Berlin · Germany
T + 49 30 56 59 88 35 F + 49 30 56 59 88 34
customer care.cts@ametek.com
www.ametek-cts.com

© March 2021 Teseq®
Specifications subject to change without notice.
Teseq® is an ISO-registered company. Its products are designed and manufactured under the strict quality and environmental requirements of the ISO 9001. This document has been carefully checked. However, Teseq® does not assume any liability for errors or inaccuracies.

82-259601 E01 March 2021

Model No. and options

Part number	Description
259601	HV-AN 200 5 µH high voltage artificial network, unshielded, butterfly screw, for Automotive conform with ISO 7637-2 and HV part of CISPR 12 (draft), CISPR 25, ECE No.10 R05 / R06, ISO 11452-1 and ISO 7637-4
97-259601	HV-AN 200-TC Traceable calibration (ISO17025), order only with the device
98-259601	HV-AN 200-ACC Accredited calibration (ISO17025)
259603	SME HV-AN 1µH / 200 Shielded metal enclosure for two HV-AN 1µH or HV-AN 200
257521	A 50-N Termination 50 Ohms, N type, male, 1 Watt, 4 GHz