



CDND M316-16B COUPLING / DECOUPLING NETWORK FOR DIFFERENTIAL MODE (CDND)



- Coupling network designed for IEC / EN 61000-4-31
- Frequency range 150 kHz to 80 MHz
- 4 mm banana sockets
- M2 and M3 applications

IEC / EN 61000-4-31, with the title “Testing and measurement techniques–AC mains ports broadband conducted disturbance immunity test”, specifies the testing in the frequency range 150 kHz to 80 MHz. Teseq offers with CDND M316-16B a specific coupling / decoupling network for this standard requirement. The CDND M316-16B provides a longitudinal conversion loss (LCL) of 16 dB in order to inject the common mode signal as well as the differential mode signal to the EUT port. It can be used for both application with and without protective earth connection.

Electrical specification

Frequency range:	150 kHz to 80 MHz
Impedance EUT port (CM), L+N to PE:	(25 ±3) Ω, (0 ±25) °
Impedance EUT port (DM), L to N:	(100 ±25) Ω, (0 ±25) °
Impedance RF input:	50 Ω
Insertion loss (RF input to EUT) (DM):	(3 ±1) dB
Longitudinal conversion loss, EUT port:	(16 ±3) dB, with RF = 50 Ω and AC mains = 100 Ω (L to N)
Isolation (AC mains port – EUT port):	>15 dB

Common mode (CM)
 Differential mode (DM)

Maximum ratings

Voltage AC mains	250 VAC, 50 Hz
Current AC mains	16 A
RF input (noise signal 150 kHz to 80 MHz)	45 W/Hz (–32.5 dBm/Hz) for 15 minutes

Connectors

L (black), N, PE	4 mm safety banana, jack (female)
RF input	BNC, jack (female)

Mechanical specifications and environmental conditions

Size (W x H x D):	200 mm x 200 mm x 470 mm
Weight:	approx. 12.5 kg
Classification:	Indoor use only
Operating temperature:	+5 °C to +30 °C
Relative humidity:	up to 80 %

CDND M316-16B

COUPLING / DECOUPLING NETWORK FOR DIFFERENTIAL MODE (CDND)

Example setup for test level setting

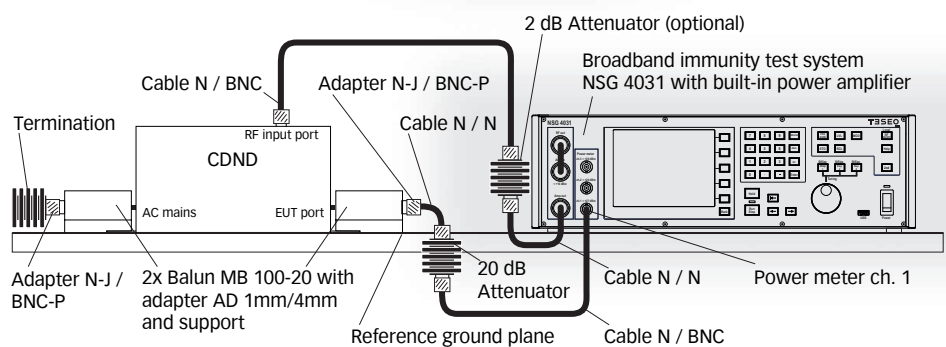

Example setup for testing

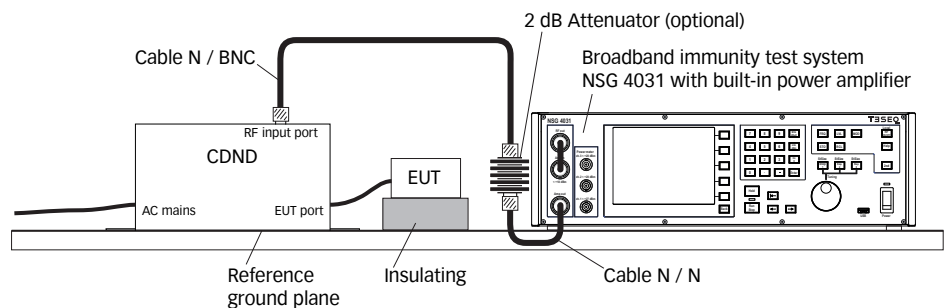

Model No. and options

AMETEK CTS Europe GmbH
 Landsberger Str. 255 · 12623 Berlin · Germany
 T +49 30 56 59 88 35 F +49 30 56 59 88 34
 info.rf.cts@ametek.com www.teseq.com

© March 2018 Teseq®
 Specifications subject to change without notice.
 Teseq® is an ISO-registered company. Its products
 are designed and manufactured under the strict
 quality and environmental requirements of the ISO
 9001. This document has been carefully checked.
 However, Teseq® does not assume any liability for
 errors or inaccuracies.

82-257807 E02 March 2018

Part number	Description
257807	CDND M316-16B Coupling Decoupling Network for differential mode according IEC 61000-4-31, type M2/M3, 16 A, banana
97-247756	CDND M316-16-TC Traceable calibration (ISO17025) for IEC 61000-4-31 requirements, order only with the unit
257802	CAS CDND31 Calibration kit for CDND M316-16, incl. 2x MB 100-20 (Balun 50 Ω/100 Ω), BMB 1000 (Balanced Measuring Bridge) and adapters, delivered in storage case, traceable calibration included