

Technical Notes from Laplace Instruments Ltd

EMC Emissions measurement.

Pre selectors... what, why and when?

Most of us working in EMC will have heard comments about pre-selectors. This article sets out to explain what these are, why they may be necessary and when you should use one.

A check with the EMC 'bible' (CISPR16) will show that all radiated and conducted emission levels should be measured with a 'measuring receiver'. Most of us will be using a 'spectrum analyser' or EMC analyser, **not** a measuring receiver! The essential difference between an analyser and a receiver is the 'pre-selector'. This unfortunately tends to be an expensive item, judging by the price differential between analysers and receivers. However, if the bible thinks it is important, perhaps we ought to at least know what it is and why it is apparently necessary.

For many applications, the spectrum analyser is perfectly adequate, provided that it has 'real' QP and average detectors and an adequate dynamic range. However, there are circumstances when a spectrum analyser will give false results. This article will explain how to check for these 'circumstances' and how to avoid them.

All RF spectrum analysers, regardless of manufacturer or type, even the PC software controlled varieties, use the same basic principle of operation. This is shown in fig 1.

Fig 1 Block diagram for a Spectrum Analyser

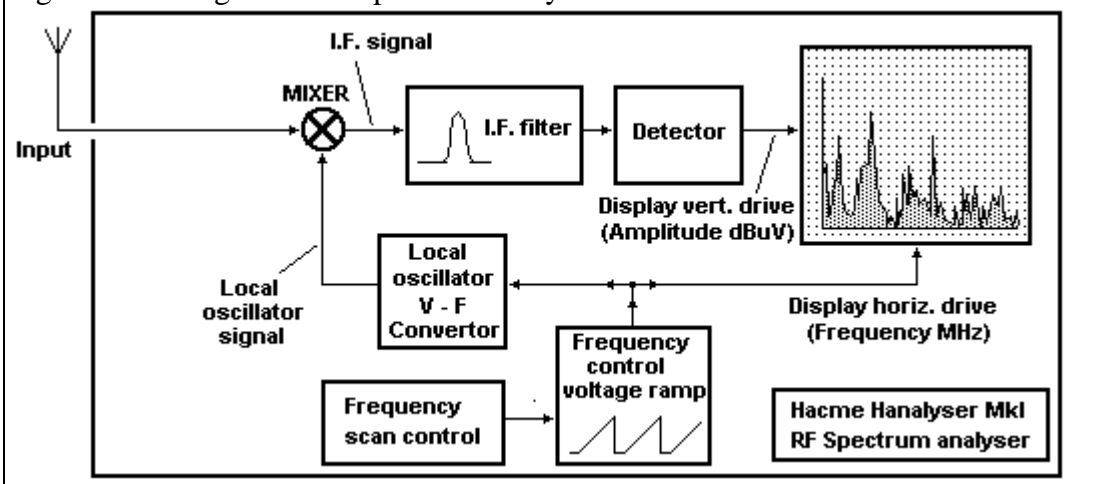

The essential features are the MIXER which mixes the incoming signal with a pure frequency from a local oscillator. The resulting mixer output includes sum and difference frequencies which are filtered to produce a fixed frequency I.F. signal which is detected and fed to the vertical scale on the display.

Note that a real analyser is far more complex, typically using three I.F. stages and complex filtering to eliminate all unwanted mixing products.

The key item in this analysis is this mixer. Note that the incoming signal is effectively fed directly to this device, so it has to cope with all frequencies and has a broadband characteristic. Mixers have only a certain amount of dynamic range. Dynamic range is

the difference between the strongest signal we can cope with and the smallest signal we can see. This 'window' can be moved up and down by switching attenuators in or out.

Assume we are testing for radiated emissions on an outdoor site.

The FM broadcast signals may have a strength of 90dBuV/m or more. Our limit levels are of the order of 30 to 40dBuV/m and we need to 'see' that our emissions are significantly below this level, say down to 20dBuV/m. This implies a dynamic range of at least $(90 - 20) = 70\text{dB}$ and that assumes the attenuator is set to the optimum level.

Some analysers have mixers that have only 50dB dynamic range...so you can visualise the problem!

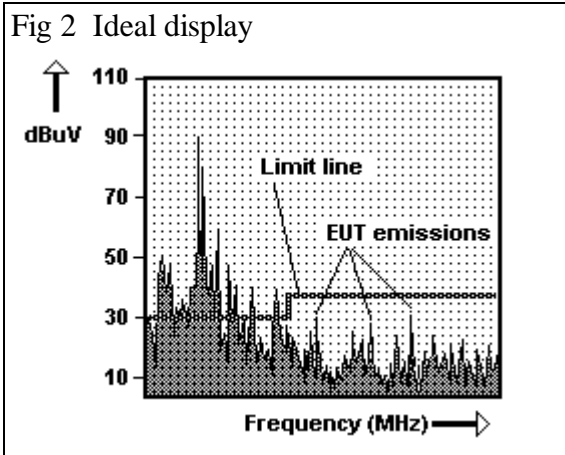

If we have an analyser with 50dB dynamic range, and need to measure the emissions in the above scenario, we could set the attenuators so that the baseline is at 20dB. This should enable the measurement of the EUT emissions anticipated in the 20 - 30dB range. Unfortunately, this now means that the strongest signal we can properly see is 70dB.

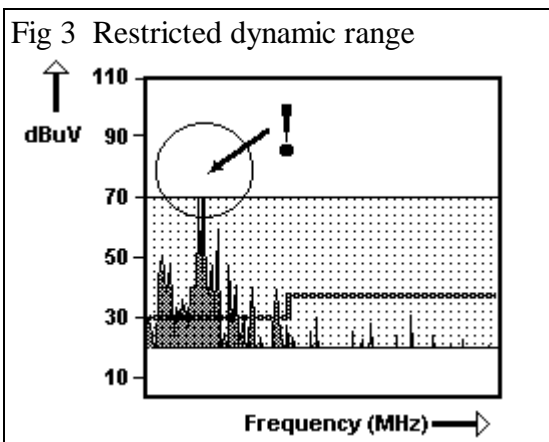

So the strong 90dB components in the spectrum will be 'overloading' the mixer. This is akin to the overloading of an audio amplifier. Although it is not an overload in the sense of causing a catastrophic failure, it is pushing the circuit into a non-linear mode of operation and hence will cause signal distortion. This can be clearly heard on an audio amplifier, but with a spectrum analyser there is no easy way to tell.

These 90dB components will be 'compressed' by at least 20dB to fit within the range of the analyser output. That means that the considerable signal energy apparently lost due to this compression will in fact appear as false indications at other frequencies.

Fig 4 Compression

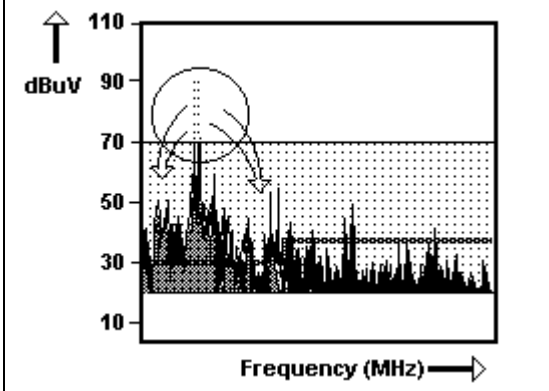

The black areas in the diagram show how this excess energy totally corrupts the real signal spectrum both as false harmonics and other random effects. This distorted result will look perfectly valid. There is no way of telling whether the result is good or is corrupted by 'compression' simply by looking at the screen.

A simple test we can always apply is to increase the attenuator by 10dB. The result should be an identical trace, but moved down by 10dB. If compression was present, the trace not only move down, but will change because the amount of compression will have been reduced by 10dB. It is good practice to always make this check if in doubt about the input signal level.

Fig 5 Not the answer

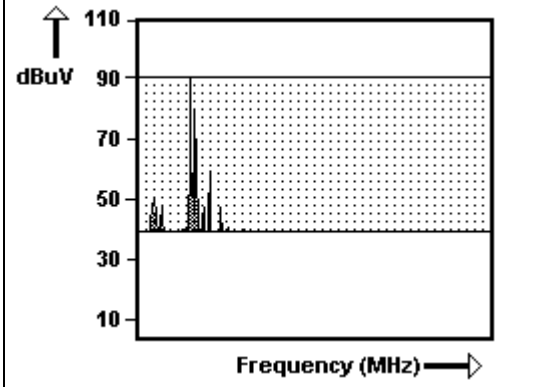

To avoid the problem of compression, the attenuator should be increased so that the strongest signal is within the range of the analyser. This will completely eliminate the problem of compression, but now the results are effectively useless because we cannot see the signals of interest.

Clearly, we need a better answer! This is where the measuring receiver enters the arena. The major difference between the receiver and a spectrum analyser is the addition of a **pre-selector**.

Fig 6 Receiver block diagram

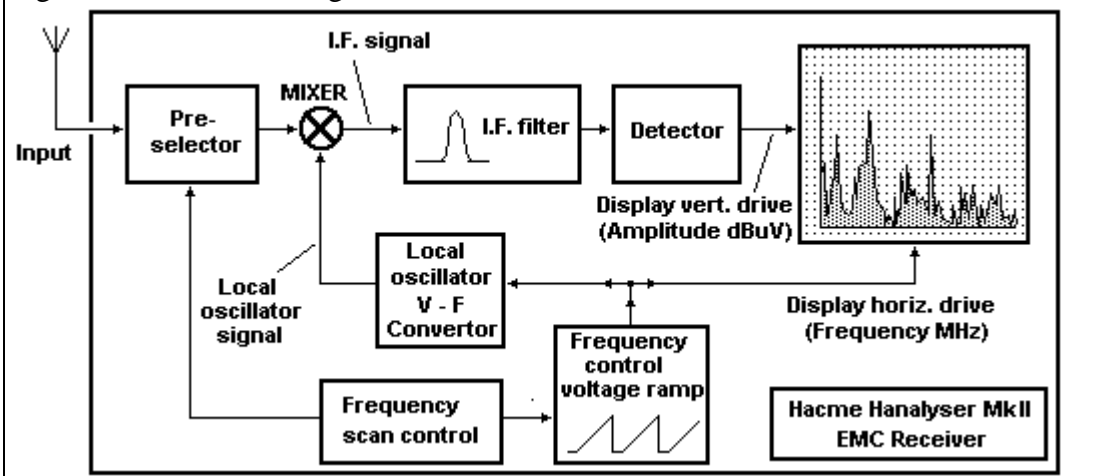

The pre-selector is really a series of bandpass filters which can be switched into use one at a time. The total range of frequencies covered is matched to the frequency

range of the analyser. For an EMC band B analyser (150KHz - 30MHz) the pre-selector may have 7 bands to cover this range.

Band No.	Pass band (MHz)	
	Start	Finish
1	0.15	0.3
2	0.3	0.6
3	0.6	1.2
4	1.2	2.5
5	2.5	5.0
6	5.0	12.0
7	12.0 </td <td>30.0</td>	30.0

The Laplace RF900 series pre-selectors has bands split as shown in table 1. These can be automatically switched in one at a time as the analyser is scanning. Operation is transparent to the user.

The effect of the pre-selector is to allow only a narrow band of frequencies through to the mixer. This band includes the frequency currently being swept. As the sweep frequency increases and reaches the end of one band, the pre-selector switches over to the next highest.

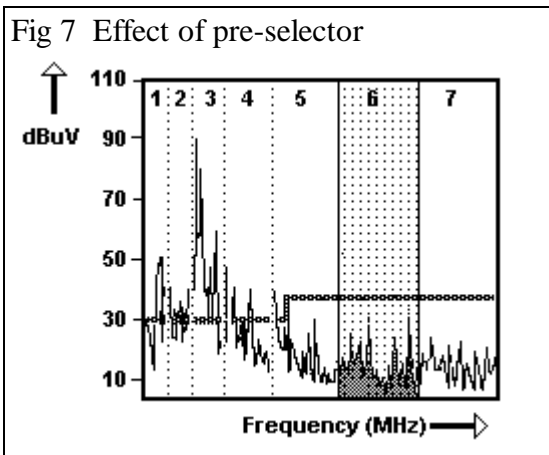

The diagram shows the effect of the pre-selector as the analyser sweeps through band 6. Only band 6 signals are visible to the mixer, all other frequencies having been attenuated by the pre-selector filter. In particular, the high energy signals are removed and the sensitivity of the 'analyser' can be increased by reducing the attenuators so that the low level EUT signals can be properly measured without suffering compression.

Although some of the examples above are related to band C, the radiated emission band above 30MHz, some of the worst signals (from a compression point of view) are experienced in conducted emissions testing. Here the signals from many sources are highly impulsive (eg. Phase angle power controllers, commutator motors etc....) These generate considerable broadband energy (see) despite a relatively low average or QP reading at any one frequency. Under these circumstances, pre-selectors are almost essential unless the analyser has exceptional dynamic range (110dB or more). The Laplace range of pre-selectors feature manually switched and automatic versions. Either of these can be used with any spectrum analyser, providing a vast improvement in effective performance by emulating the action of a receiver.

A real example.

These plots were acquired with a Laplace SA1000 analyser, standard 16A LISN and RF910 pre-selector. The product was a table lamp fitted with a light dimmer. This dimmer was set at the lowest of two intermediate settings. The first sweep (fig 8) was taken with no pre-selector, the second (fig 9) with the pre-selector in circuit.

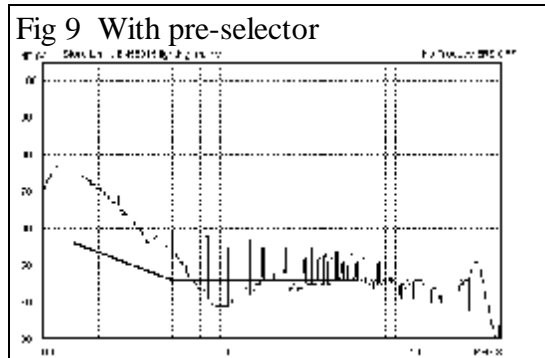
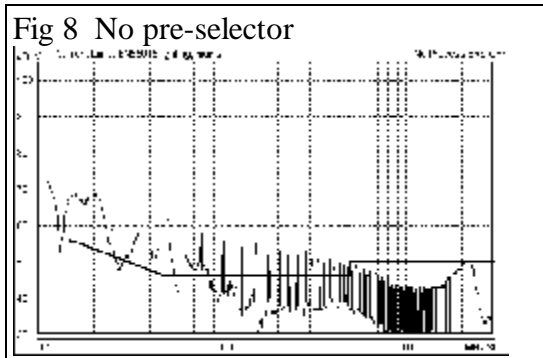

The results are quite different! Note that the ‘corruption’ of the spectrum has had the effect of generally reducing the measured levels. This is a feature of broadband compression, whereas compression due to narrowband signals (such as used in the example of FM transmissions above) tends to result generally in an increase of levels.

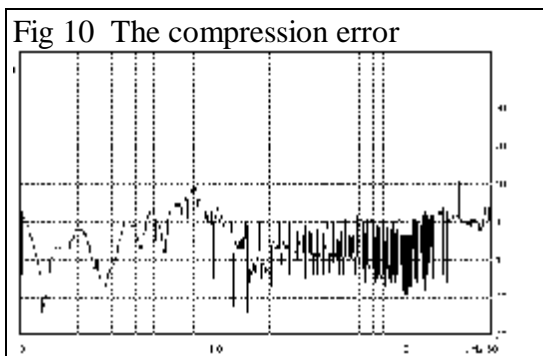

The final diagram Fig 10 is a plot of the difference between the two plots. This clearly shows that errors in excess of 10dB, up to 20dB in places did occur.

Points to note are:

- Compression can affect any spectrum analyser. (I have personally seen it happen with unsuspecting users of the most expensive instruments)
- Many analysers do not warn the user that compression has occurred. Unless you know the signs, the ‘compressed’ results will look perfectly OK.
- Always check for compression, particularly if the signal is generally broadband in nature.
- The test for compression is to change the attenuator (increase if possible) by a known amount (eg 10dB) and check that the trace is simply shifted by the corresponding amount, but is otherwise identical. If there are other changes, compression is present.
- If you are dealing with signals that are, or may be causing compression, use a pre-selector. Both manual (RF900) and automatic (RF910) versions are available from Laplace Instruments and are compatible with any spectrum analyser.