

DCD ST - SERIES

COUPLING/DECOUPLING NETWORK FOR UNSHIELDED SYMMETRICAL INTERCONNECTION LINES (COMMUNICATION LINES)



FOR TESTS ACCORDING TO ...

- > EN 61000-4-5
- > IEC 61000-4-5
- > ITU-T K.44





DCD ST -SERIES - COUPLING DECOUPLING NETWORKS FOR UNSHIELDED COMMUNICATION LINES

Surge pulses and Telecom Surge pulses are applied to unshielded symmetrical interconnection lines (communication lines) by means of standalone coupling/decoupling networks. The DCD st-4-1 is designed for 4 lines (2 pairs) and the DCD st-8-1 for 8 lines (4 pairs). The DCD st-8-1 can be used for either 4, 2 or 1 pairs. According to IEC 61000-4-5 Ed.3, (Fig. 10) the pulses are coupled via gas arrestors and a matching resistor per line.

HIGHLIGHTS

- > As per IEC 61000-4-5 Ed.3, Fig 10/A4, ITU K.44
- > For test pulse 1.2/50 - 8/20 μ s and 10/700 μ s
- > Coupling via gas arrestor or other coupling
- > Built-in matching resistors
- > 20 mH decoupling, current compensated pairs
- > Test voltage up to 7 kV
- > Line voltage 50 V, 250 V other on request
- > Line current 1 A

APPLICATION AREAS

-  INDUSTRY
-  MEDICAL
-  RESIDENTIAL
-  TELECOM

TECHNICAL DETAILS

SURGE 1.2 / 50 US

DCD ST - SERIES - SURGE COUPLING/DECOUPLING NETWORKS FOR COMMUNICATION LINES

The AMETEK CTS coupling/ decoupling networks of the DCD st - series are designed to couple Surge pulses (1.2/50 us - 8/20 us) and Telecom Surge pulses (10/700 us) onto unshielded symmetrically operated communication lines.

The DCD st - models includes the external coupler (GTD) for coupling via gas arrestor plus the internal matching resistor R_c as per figure 10 of IEC 61000-4-5 Ed.3 with values as per the formula given by the standard. All lines are subjected to the test pulse simultaneously with respect to ground.

The DCD st - series also include the required decoupling inductors of 20 mH for each line (pairwise current compensated). To protect the auxiliary equipment being needed for testing the DUT an additional protection circuit is integrated at the communication line input.

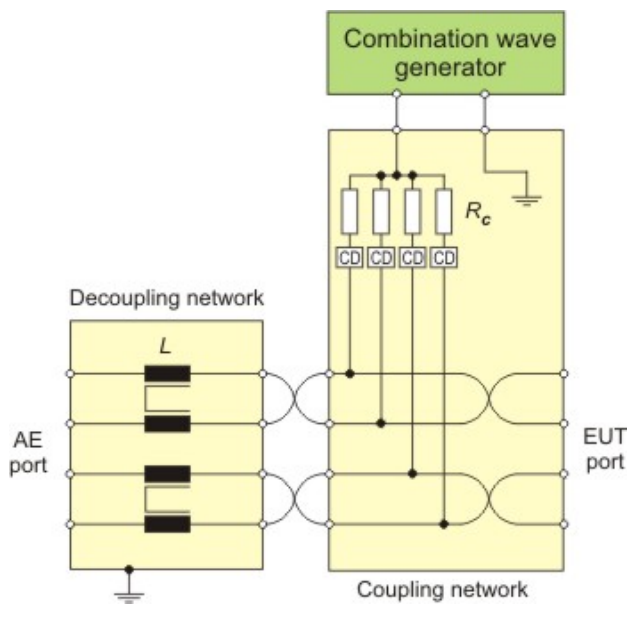

SURGE 10/700 US

DCD ST - SERIES - TELECOM SURGE COUPLING/DECOUPLING NETWORKS FOR COMMUNICATION LINES

The DCD st - series is designed as per figure A4 of IEC 61000-4-5 Ed.3 without primary protector. If required, an additional primary protector must be integrated according to the user specifications.

With short circuit bridges and individual designed coupling devices the user can easily modify the coupling mode and number of tested lines to the requirements.

AMETEK CTS offers DCD st-4-1 or DCD st-8-1 coupling/decoupling networks for test voltages up to and 7 kV.

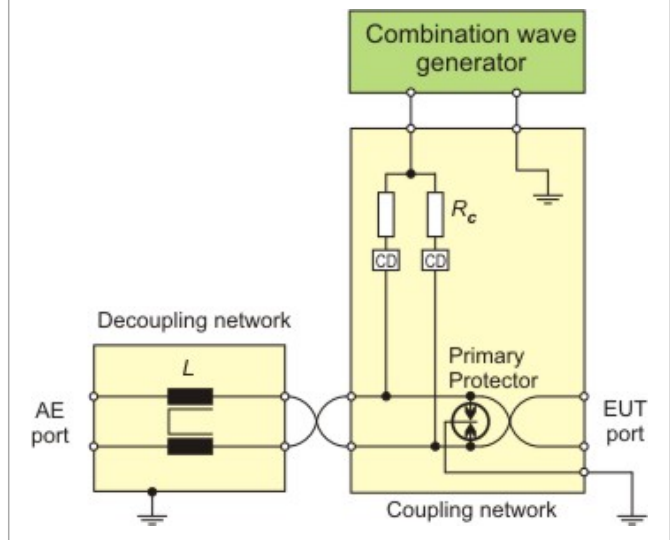

TECHNICAL DETAILS

MODELL OVERVIEW

MODELS FOR 5 KV AND 7 KV

DCD 5 st-4-1	5 kV, 4 lines (2 pairs),
DCD 5 st-8-1	5 kV, 8 lines (4 pairs),
DCD 7 st-4-1	7 kV, 4 lines (2 pairs),
DCD 7 st-8-1	7 kV, 8 lines (4 pairs),

DCD 5 ST-4-1 FOR 4 UNSHIELDED SYMMETRICAL LINES

COMMON DATA DCD 5 ST-4-1

CDN	for 4 lines (2 pairs) as per IEC 61000-4-5 Ed.3, - Surge pulses (Fig. 10), - Telecom Surge (Fig. A4)
Max. voltage	5 kV impulse
Line voltage	max. 50 V / 250 V
Line current	max. 1 A
Coupling	Selectable - GDT, gas arrestor - Individual CD
Matching resistors Rc	Surge Pulse 1.2/50 μ s, 4 x 160 Ohm (2 pairs), 2 x 80 Ohm (1 pair)
Matching resistors Rc	Telecom surge 10/700 μ s, 4 x 25 Ohm
Decoupling	20 mH decoupling inductor, \pm 10 % tolerance, pairwise current compensated
Residual voltage	at the AE port, 5 kV impulse 88 V (1.2/50 μ s), 80 V (10/700 μ s)
Signal Bandwidth	100 kHz with 600 Ohm load
Data rate	up to 1 MBit/s

GENERAL DATA DCD 5 ST-4-1

Connectors	4 mm safety lab sockets
Dimensions	19" 3HU, 447 x 400 x 143 mm
Weight	approx. 15 kg

DCD 5 ST-8-1 FOR 8 UNSHIELDED SYMMETRICAL LINES

COMMON DATA DCD 5 ST-8-1

CDN	for 8 lines (4 pairs) as per IEC 61000-4-5 Ed.3, - Surge pulses (Fig. 10), - Telecom Surge (Fig. A4)
Max. voltage	5 kV impulse
Line voltage	max. 50 V / 250 V
Line current	max. 1 A
Coupling	Selectable - GDT, gas arrestor - Individual CD
Matching resistors Rc	Surge Pulse 1.2/50 μ s, 8 x 320 Ohm (4 pairs), 4 x 160 Ohm (2 pairs), 2 x 80 Ohm (1 pair)
Matching resistors Rc	Telecom surge 10/700 μ s, 8 x 25 Ohm
Decoupling	20 mH decoupling inductor, \pm 10 % tolerance pairwise current compensated
Residual voltage	at the AE port, 5 kV impulse 85 V (1.2/50 μ s), 60 V (10/700 μ s)
Signal Bandwidth	100 kHz with 600 Ohm load
Data rate	up to 1 MBit/s

GENERAL DATA DCD 5 ST-8-1

Connectors	4 mm safety lab sockets
Dimensions	19" 3 HU, 447 x 400 x 143 mm
Weight	approx. 22 kg

TECHNICAL DETAILS

DCD 7 ST-4-1 FOR 4 UNSHIELDED SYMMETRICAL LINES

COMMON DATA DCD 7 ST-4-1

CDN	for 4 lines (2 pairs) as per IEC 61000-4-5 Ed.3, - Surge pulses (Fig. 10), - Telecom Surge (Fig. A4)
Max. voltage	7 kV impulse
Line voltage	max. 50 V / 250 V
Line current	max. 1 A
Coupling	Selectable - GDT, gas arrestor - Individual CD
Matching resistors Rc	Surge Pulse 1.2/50 μ s, 4 x 160 Ohm (2 pairs), 2 x 80 Ohm (1 pair)
Matching resistors Rc	Telecom surge 10/700 μ s, 4 x 25 Ohm
Decoupling	20 mH decoupling inductor, \pm 10 % tolerance, pairwise current compensated
Residual voltage	at the AE port, 5 kV impulse 88 V (1.2/50 μ s), 80 V (10/700 μ s)
Signal Bandwidth	100 kHz with 600 Ohm load
Data Rate	up to 1 MBit/s

GENERAL DATA DCD 7 ST-4-1

Connectors	4 mm safety lab sockets
Dimensions	19" 6 HU, 447 x 400 x 286 mm
Weight	Approx. 20 kg

DCD 7 ST-8-1 FOR 8 UNSHIELDED SYMMETRICAL LINES

COMMON DATA DCD 7 ST-8-1

CDN	for 8 lines (4 pairs) as per IEC 61000-4-5 Ed.3, - Surge pulses (Fig. 10), - Telecom Surge (Fig. A4)
Max. voltage	7 kV impulse
Line voltage	max. 50 V / 250 V
Line current	max. 1 A
Coupling	Selectable - GDT, gas arrestor - Individual CD
Matching resistors Rc	Surge Pulse 1.2/50 μ s, 8 x 320 Ohm (4 pairs), 4 x 160 Ohm (2 pairs), 2 x 80 Ohm (1 pair)
Matching resistors Rc	Telecom surge 10/700 μ s, 8 x 25 Ohm
Decoupling	20 mH decoupling inductor, \pm 10 % tolerance pairwise current compensated
Residual voltage	at the AE port, 5 kV impulse 85 V (1.2/50 μ s), 60 V (10/700 μ s)
Signal Bandwidth	100 kHz with 600 Ohm load
Data rate	up to 1 MBit/s

GENERAL DATA DCD 7 ST-8-1

Connectors	4 mm safety lab sockets
Dimensions	19" 6 HU, 447 x 400 x 286 mm
Weight	Approx. 27 kg

TECHNICAL DETAILS

ACCESSORIES FOR ALL DCD MODELS

ACCESSORIES DCD 5/7 ST-4-1

Coupling device	4 x GDT, Gas discharge tube
AE Protection	1 x DPM 50-1
HVS - Banana - Banana	HV cable 1.0 m 1 x red (HV) 1 x black (COM)
Earth cable	Art. 10945 1 x 0.6 m yellow-green 2 x M4 screws with toothed washer
Short circuit bridges	8 bridges, 4 x (25/160) Ohm resistors, 4 x coupling
Safety lab cables	Art:105886 8 x 0.25 m Safety lab cables

ACCESSORIES DCD 5/7 ST-8-1

Coupling device	8 x GDT, Gas discharge tube
AE Protection	2 x DPM 50-1
HVS - Banana - Banana	HV cable 1.0 m 1 x red (HV) 1 x black (COM)
Earth cable	Art. 10945 1 x 0.6 m yellow-green 2 x M4 screws with toothed washer
SCC Short circuit bridges	16 bridges, 8 x (25/320) Ohm resistors, 8 x coupling
Safety lab cables	Art:105886 18 x 0.25m Safety lab cables
Manual	English and German manual on CD

OPTIONS

COUPLING DEVICES

ABD Plug	Avalanche Breaking Diode Coupling 140 V diode for Surge 1,2/50 μ s and Telecom Surge 10/700 μ s Max. Impulse voltage 7 kV
GDT	Gas Discharge Tube Coupling via 90 V gas arrester for Surge 1,2/50 μ s and Telecom Surge 10/700 μ s Max. Impulse voltage 7 kV

PROTECTION DEVICES

Protection unit	Module with 4 lines 2 units are required for DCD with 8 lines
DPM 50-1	Diode protection module 50 V, bidirectional diodes, V _{max} : 35 VAC, 50 VDC, Impedance to GND: 1 kOhm
DPM 50	Diode protection module 50 V, bidirectional diodes, V _{max} : 35 VAC, 50 VDC, Impedance to GND: Open circuit
VPM 250-100	Varistor protection module 250 V, Varistor 250 VAC, 350 VDC, Impedance to GND: 100 kOhm

GENERAL DATA

ENVIRONMENT

Temperature	5 - 40 °C
Rel. humidity	10 - 90 %, non-condensing
Atmospheric pressure	86 kPa (860 mbar) to 106 kPa (1,060 mbar)

COMPETENCE WHEREVER YOU ARE

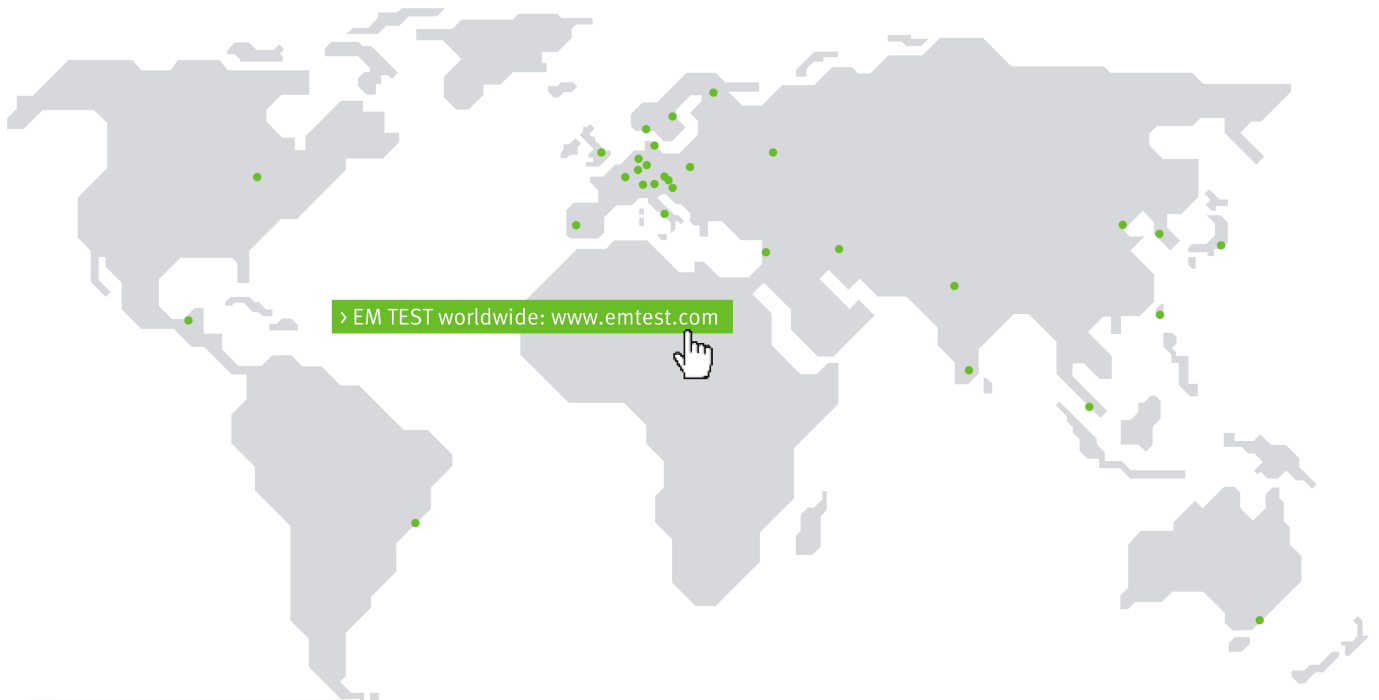

> EM TEST worldwide: www.emtest.com

Accelonix BV
Luchthavenweg 18b • NL-5657 EB •
Eindhoven • The Netherlands •
T: +31 40 750 1650 • E: info@accelonix.nl

CONTACT EM TEST DIRECTLY

Switzerland

AMETEK CTS GmbH > Sternenhofstraße 15 > 4153 Reinach > Switzerland
Phone +41 (0)61 204 41 11 > Fax +41 (0)61 204 41 00
Internet: www.ametek-cts.com > E-mail: sales.conducted.cts@ametek.com

Germany

AMETEK CTS Europe GmbH > Customer Care Center EMEA > Lünener Straße 211
> 59174 Kamen > Germany
Phone +49 (0) 2307 26070-0 > Fax +49 (0) 2307 17050
Internet: www.ametek-cts.com > E-mail: info.cts.de@ametek.com

Poland

AMETEK CTS Europe GmbH > Biuro w Polsce > ul. Twarda 44 > 00-831 Warsaw > Poland
Phone +48 (0) 518 643 12
Internet: www.ametek-cts.com > E-mail: Infopolska.cts@ametek.com

USA / Canada

AMETEK CTS US > 52 Mayfield Ave > Edison > NJ 08837 > USA
Phone +1 732 417 0501
Internet: www.ametek-cts.com > E-mail: usasales.cts@ametek.com

P.R. China

E & S Test Technology Limited > Rm 913, Leftbank >
No. 68 Bei Si Huan Xi Lu > Haidian District > Beijing 100080 > P.R. China
Phone +86 (0)10 82 67 60 27 > Fax +86 (0)10 82 67 62 38
Internet: www.emtest.com > E-mail: info@emtest.com.cn

Republic of Korea

EM TEST Korea Limited > #405 > WooYeon Plaza > #986-8 > YoungDeok-dong >
Giheung-gu > Yongin-si > Gyeonggi-do > Korea
Phone +82 (31) 216 8616 > Fax +82 (31) 216 8616
Internet: www.emtest.co.kr > E-mail: sales@emtest.co.kr

Singapore

AMETEK Singapore Pte. Ltd > No. 43 Changi South Avenue 2 > 04-01 Singapore
48164
Internet: www.ametek-cts.com > E-mail: singaporesales.cts@ametek.com

Great Britain

AMETEK GB > 5 Ashville Way > Molly Millars Lane > Wokingham > Berkshire
RG41 2 PL > Great Britain
Phone +44 845 074 0660
Internet: www.ametek-cts.com

Information about scope of delivery, visual design and technical data correspond with the state of development at time of release. Subject to change without further notice.