

SERIES F-106A Four Sides Radius Tab Tool with Double Cross Groove

Accelonix BV
 Luchthavenweg 18b • NL-5657 EB •
 Eindhoven • The Netherlands •
 T: +31 40 750 1650 • E: info@accelonix.nl

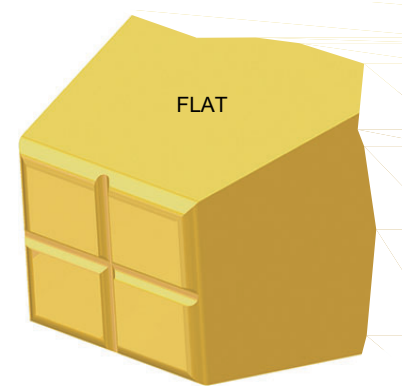
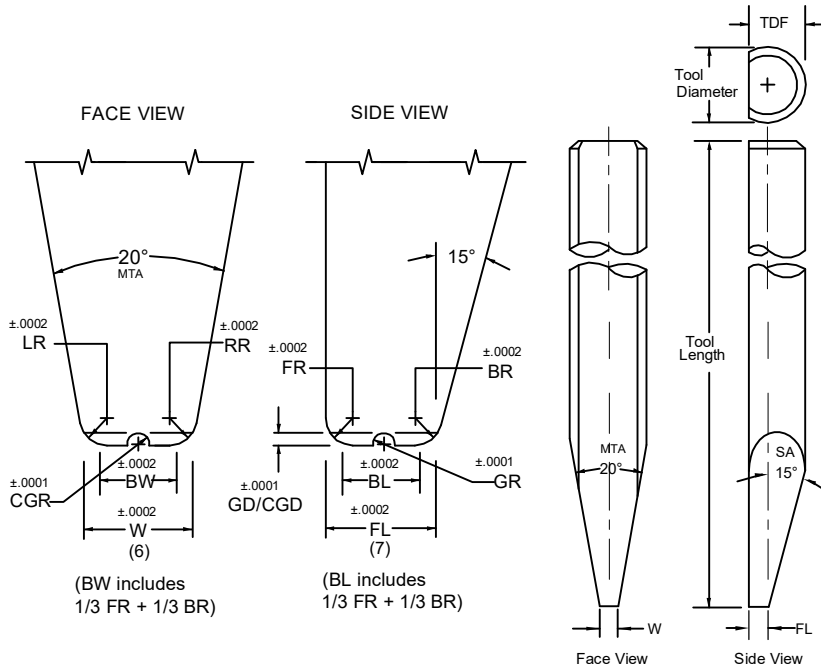

MTA = MAIN TAPER ANGLE
 SA = SIDE VIEW ANGLE

Special dimensions available upon request.
 Dimensions not shown please specify.

We recommend ceramic material for all gold wire bonding for optimum results.

	TD		TDF	
	in.	mm	in.	mm
1/16	.0624	1.59	.0460	1.17
	.0784	1.99	.0630	1.60
3/32	.0937	2.38	.0880	2.24
	.1180	3.00	.0985	2.50
1/8	.1249	3.17	.0937	2.38
1/8	.1249	3.17	.1180	3.00

A15 OPTION (ROTATION 45°)

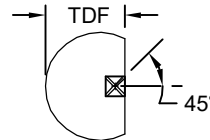

SAMPLE PART NUMBER: M-F-106A-1/16-1-.004X.004-M-E-E-.001-*
SYMBOL EXPLANATION:

- | | | | | | | | | | | | | |
|---|------------------|--------------------|--------------------------------------|------------------------------------|--|--|--|--|--|---|--|--|
| 1. MATERIAL: | 2. | 3. | 4. | 5. | 6. | 7. | 8. | 9. | 10. | 11. | 12. | |
| M = Ceramic
C = Tungsten Carbide
T = Titanium
All other: Material Selection Guide Tool Tips | SERIES: F | STYLE: 106A | TOOL DIAMETER: Please specify | TOOL LENGTH: Please specify | BOND WIDTH: (BW) Please specify | BOND LENGTH: (BL) Please specify (includes 1/3 FR + 1/3 BR) | FOOT FINISH:
M = Matte, better coupling for thermosonic gold bonding
P = Polished FR, BR, & Bond Flat for thermocompression gold bonding
MP = Polished FR, BR, and Matte Bond Flat. For ultrasonic aluminum bonding. | FRONT/BACK RADIUS:
See Option Chart below. | LEFT/RIGHT RADIUS:
See Option Chart below. | WIRE Ø:
Please specify
Wire Ø / Groove Ratios:
GR/CGR=60° of wire Ø
GD/CGD=35° of wire Ø | TOOL OPTION:
Please specify
MTA, A15 or see Tool Options | |

RADIUS OPTION CHART	OPTION LETTER			A	B	C	D	E	F	G	H	I	J	K	L	M	N
	FRONT RADIUS	LEFT RADIUS	in.	.0005	.0005	.0010	.0010	.0010	.0015	.0015	.0015	.0015	.0020	.0020	.0020	.0020	.0020
	FR	LR	μ	13	13	25	25	25	38	38	38	38	51	51	51	51	51
	BACK RADIUS	RIGHT RADIUS	in.	0	.0005	0	.0005	.0010	0	.0005	.0010	.0015	0	.0005	.0010	.0015	.0020
			μ	0	13	0	13	25	0	13	25	38	0	13	25	38	51