

# SERIES CT-208

Conical Tip Tool with Double Protruding 'V' Radius

**Accelonix BV**  
Luchthavenweg 18b • NL-5657 EB •  
Eindhoven • The Netherlands •  
T: +31 40 750 1650 • E: info@accelonix.nl

## STANDARD ROUND

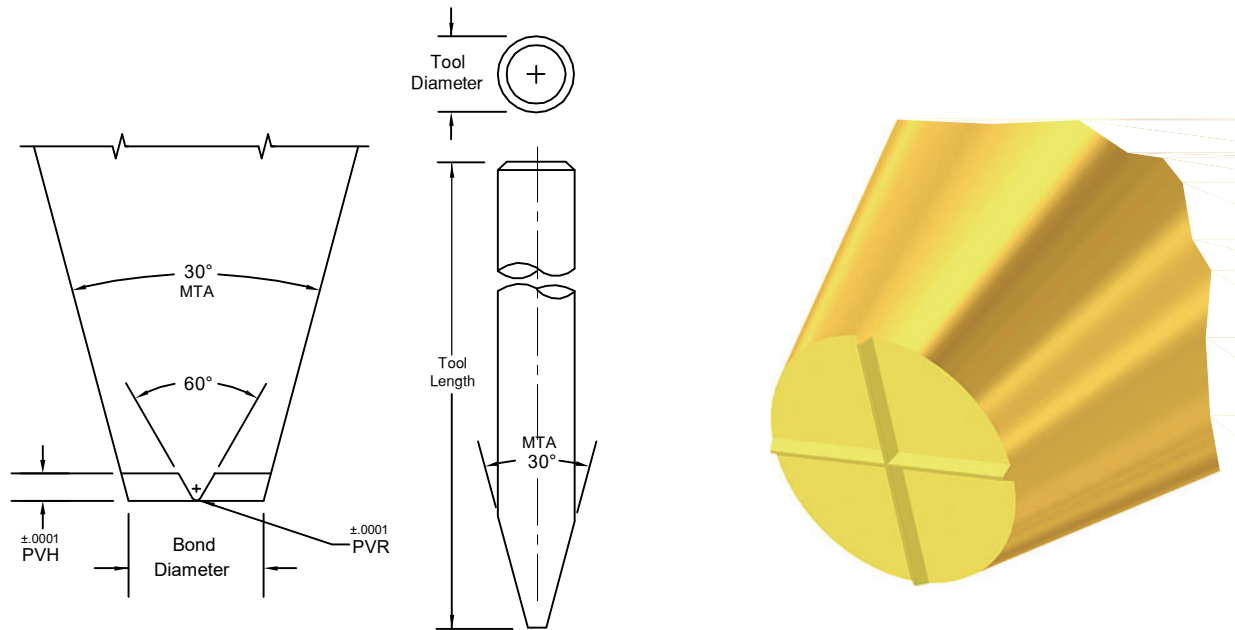

MTA = MAIN TAPER ANGLE

Special dimensions available upon request.  
Dimensions not shown please specify.  
We recommend ceramic material for all gold wire bonding for optimum results.

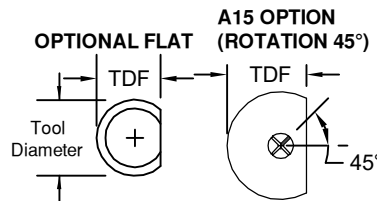

For Standard Round specify TD only  
For Optional Flat specify TD and TDF

	TD		TDF	
	in.	mm	in.	mm
1/16	.0624	1.59	.0460	1.17
	.0784	1.99	.0630	1.60
3/32	.0937	2.38	.0880	2.24
	.1180	3.00	.0985	2.50
1/8	.1249	3.17	.0937	2.38
1/8	.1249	3.17	.1180	3.00

**SAMPLE PART NUMBER: M-CT-208-1/16-1-.001-M-R-\***

- SYMBOL EXPLANATION:**
- |   |   |   |   |   |   |   |   |                                 |
|---|---|---|---|---|---|---|---|---------------------------------|
| 1                                       | 2 | 3 | 4 | 5 | 6 | 7 | 8 | 9                               |
| 1. MATERIAL:                            |   |   |   |   |   |   |   | 9. Tool Option:                 |
| M = Ceramic                             |   |   |   |   |   |   |   | Please specify MTA (Tool-Angle) |
| C = Tungsten Carbide                    |   |   |   |   |   |   |   | A15 or see Tool Options         |
| T = Titanium                            |   |   |   |   |   |   |   |                                 |
| All other: See Material Selection Guide |   |   |   |   |   |   |   |                                 |
| 2. SERIES: CT                           |   |   |   |   |   |   |   | 8. PVR / PVH:                   |
|   |   |   |   |   |   |   |   | See Option Chart below.         |
|   |   |   |   |   |   |   |   | PVR= Protruding 'V' Radius      |
|   |   |   |   |   |   |   |   | PVH= Protruding 'V' Height      |
| 3. STYLE: 208                           |   |   |   |   |   |   |   |                                 |
|   |   |   |   |   |   |   |   | 7. FOOT FINISH:                 |
|   |   |   |   |   |   |   |   | M = Matte finish                |
| 4. TOOL DIAMETER: Please specify        |   |   |   |   |   |   |   |                                 |
|   |   |   |   |   |   |   |   |                                 |
| 5. TOOL LENGTH: Please specify          |   |   |   |   |   |   |   |                                 |
|   |   |   |   |   |   |   |   |                                 |
|   |   |   |   |   |   |   |   | 6. BOND DIAMETER:               |
|   |   |   |   |   |   |   |   | Please specify                  |

OPTION LETTER		O	P	Q	R	S
PVR RADIUS	in.	0	0	.0002	.0002	.0004
	μ	0	0	5	5	10
PVH HEIGHT	in.	.0002	.0003	.0005	.0005	.0010
	μ	5	8	13	13	25