

# PCBA Inspection Tech Day

## May 15 | Eindhoven



**Accelonix**



**GOPEL**  
electronics



**comet**





**yxlon**



**Guest Wifi Network:**  
SSID: dray\_guest  
PW: WelcomeByAccelonix!

# AGENDA

09:45	<b>Welcome</b>		
10:00	<b>Inspection Xpress</b>	<b>First Article Inspection</b> 100% Visual board Analysis for first-board inspection but also for prototyping, small-series production, and final quality control.	
10:35	<b>Göpel electronics</b>	<b>3D AOI for SPI, SMT and THT</b> 3D AOI inspection of solder paste, components and solder joints. Create new AOI programs in less than ½ hour!	
11:20	<b>Comet Yxlon</b>	<b>X-Ray Inspection Technology</b> 2D, 2.5D and 3D X-Ray technology for inspecting solder joints on top and bottom without any interference.	
12:00	<b>Lunch</b>		
12:45	<b>Workshops and Live Demonstrations</b>		
	Inspection Xpress Scanner 12:45 – 13:30 	Göpel 3D AOI Basic Line 13:30 – 14:30 	Yxlon Cheetah X-Ray & CT 14:30 – 15:30 
15:30	<b>Closing and Drinks</b>		

# COMPANY PROFILE

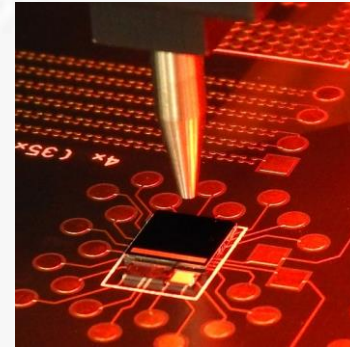
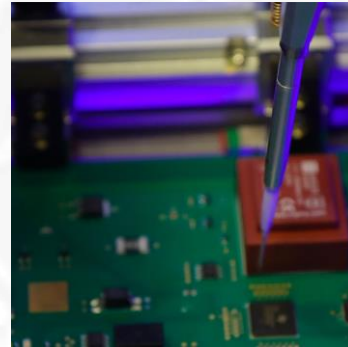

Accelonix delivers innovative solutions to electronics organisations around the world  
[www.accelonix.nl](http://www.accelonix.nl)

# ACCELONIX GROUP

Since 1993

**Independent** European distribution group

**Industry leading** suppliers and technology

Highly **trained** and **technical** staff providing local and group support

**Offices** in Benelux, France, UK, Italy, Tunisia and China

**70** employees





# ACCELONIX BV

Part of Accelonix Group since 2000

**Central Eindhoven Airport** location in Benelux

**10** employees

**Experienced** service/application engineers

Demonstration, training and application center

**Highly interactive and strong relationships** with customer and equipment manufacturers

Long-term, **excellent equipment support**



# OUR CUSTOMERS



Medical

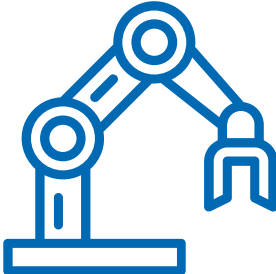

Industry



R & D / Academia



Public



Mil/Aero



Automotive



Transport



# ACCELONIX BV

## Our Solutions



**EMC & RF**



**MICRO & POWER  
ELECTRONICS  
ASSEMBLY**

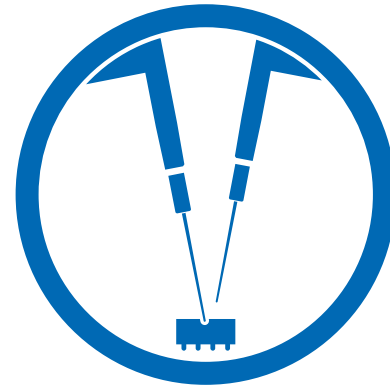

**PCBA  
INSPECTION & TEST**

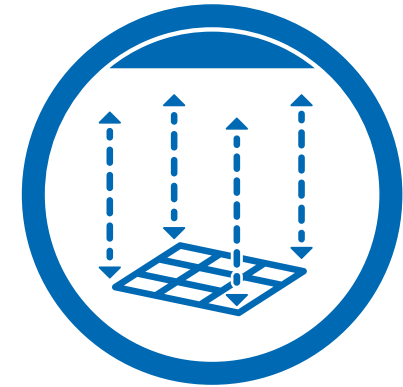

**METROLOGY**





**EMC & RF**





# ACCELONIX BV

## EMC & RF Solutions

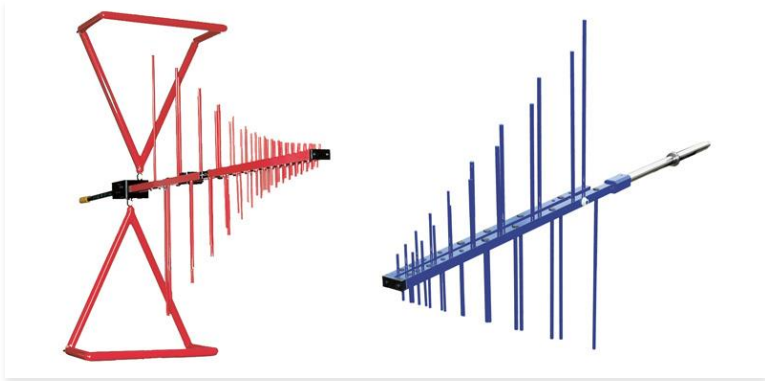

Antennas, Masts,  
Positioners & Probes



Amplifiers & Pre-Amps

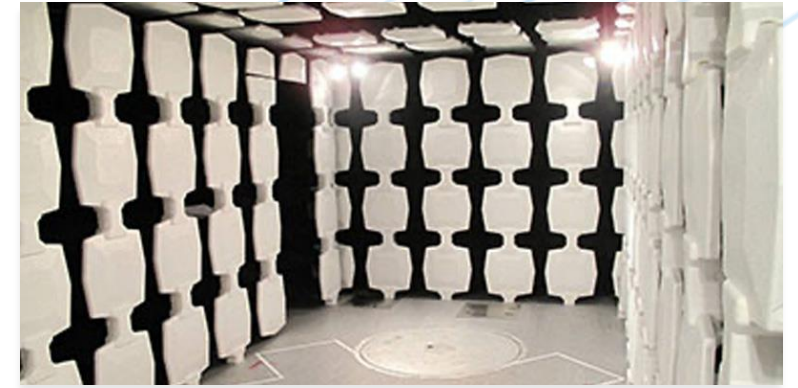

Chambers & systems

**TESEO**

Advanced Test Solutions for EMC

**MILMEGA**

RF/Microwave Amplifiers

**AMETEK**  
COMPLIANCE TEST SOLUTIONS

**FCC**

Fischer Custom Communications, Inc.

**iET**

IET LABS, INC.  
In the GenRad tradition

**Chroma**

Advancing Excellence

**emtest**  
the benchmark for emc

**ETS-LINDGREN**  
An ESCO Technologies Company



**MPE**  
Quality. Reliability. Performance.

**HUNTRON**



Laplace Instruments Ltd



# ACCELONIX BV

## EMC & RF Solutions



Harmonics & Flicker



Automotive EMC

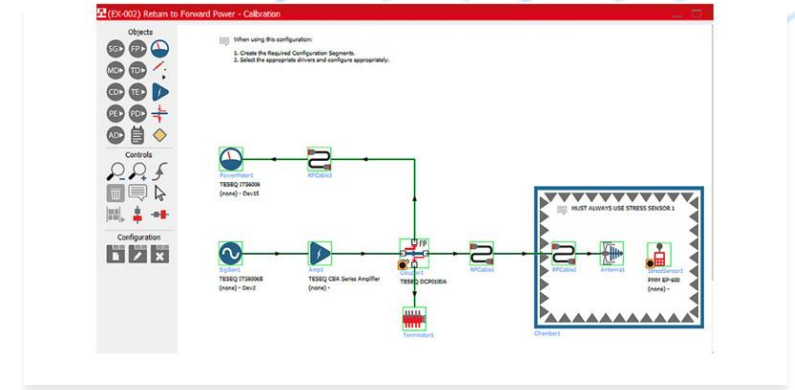

EMC Software



Advanced Test Solutions for EMC



RF/Microwave Amplifiers



COMPLIANCE TEST SOLUTIONS



Fischer Custom Communications, Inc.



IET LABS, INC.  
In the GenRad tradition



Advancing Excellence



the benchmark for emc



An ESCO Technologies Company



MPE  
Quality. Reliability. Performance.



Laplace Instruments Ltd



# ACCELONIX BV

## EMC & RF Solutions



EMI & Tempest Filters



GTEM & Test Cells



MIL STD Test



Advanced Test Solutions for EMC



RF/Microwave Amplifiers



COMPLIANCE TEST SOLUTIONS



Fischer Custom Communications, Inc.



IET LABS, INC.  
In the GenRad tradition



Advancing Excellence



the benchmark for emc



An ESCO Technologies Company



MPE  
Quality. Reliability. Performance.



Laplace Instruments Ltd



# ACCELONIX BV

## EMC & RF Solutions



RF Coupling Networks & Devices



RF LISN & ISN



RF Immunity Test



Advanced Test Solutions for EMC



RF/Microwave Amplifiers



COMPLIANCE TEST SOLUTIONS



Fischer Custom Communications, Inc.



IET LABS, INC.  
in the GenRad tradition



Advancing Excellence



the benchmark for emc



An ESCO Technologies Company



MPE  
Quality. Reliability. Performance.



Laplace Instruments Ltd





# ACCELONIX BV

## EMC & RF Solutions



Transient Immunity Test



RF Emission Test



Advanced Test Solutions for EMC



RF/Microwave Amplifiers



COMPLIANCE TEST SOLUTIONS



Fischer Custom Communications, Inc.



IET LABS, INC.  
in the GenRad tradition



Advancing Excellence



the benchmark for emc



An ESCO Technologies Company



MPE  
Quality. Reliability. Performance.



Laplace Instruments Ltd



# ACCELONIX BV

## EMC & RF Solutions



EMI Receivers



Test & Measurement



Advanced Test Solutions for EMC



RF/Microwave Amplifiers



COMPLIANCE TEST SOLUTIONS



Fischer Custom Communications, Inc.



IET LABS, INC.  
in the GenRad tradition



Advancing Excellence



the benchmark for emc



An ESCO Technologies Company



MPE  
Quality. Reliability. Performance.



Laplace Instruments Ltd







**MICRO & POWER ELECTRONICS  
ASSEMBLY**



# ACCELONIX BV

Micro | Power Electronics Packaging Solutions

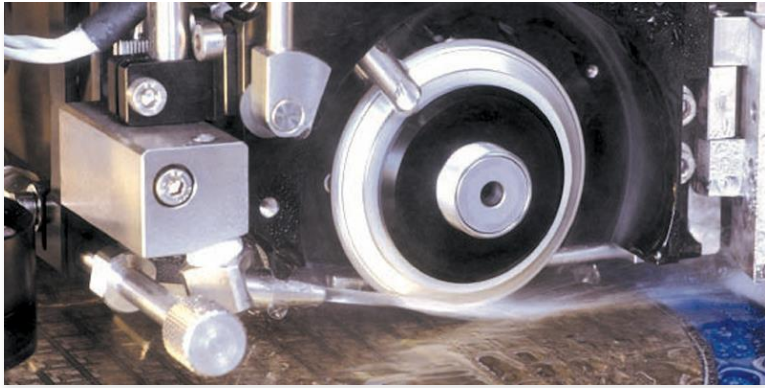

Dicing

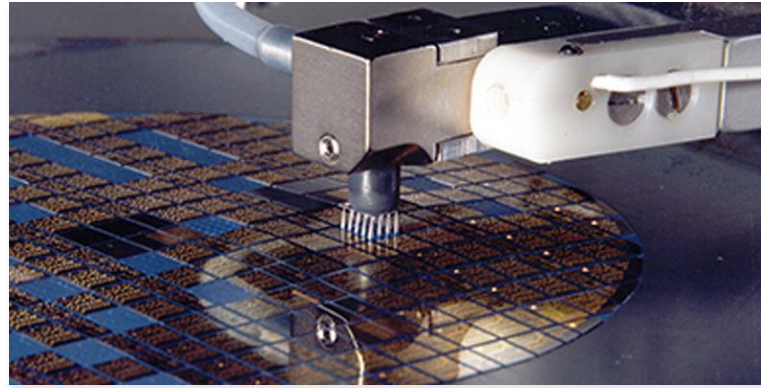

Die Sorting

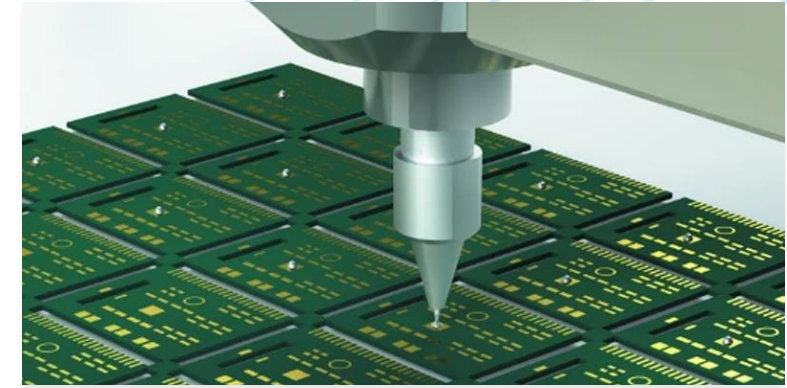

Dispensing



# ACCELONIX BV

Micro | Power Electronics Packaging Solutions

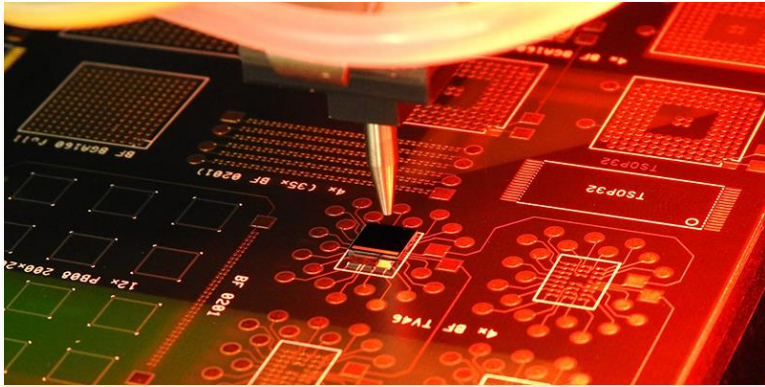

Die Bonding

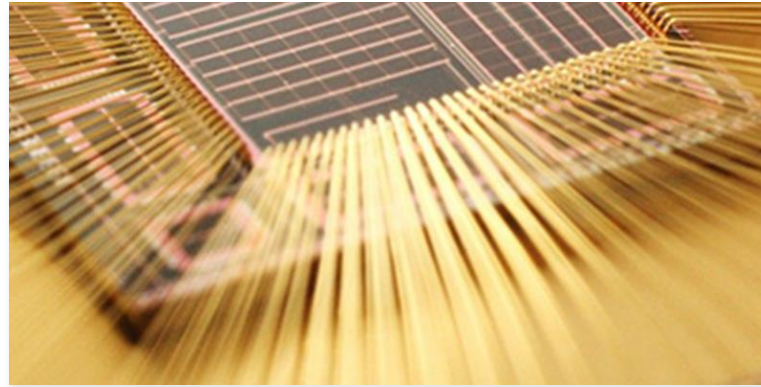

Wire Bonding

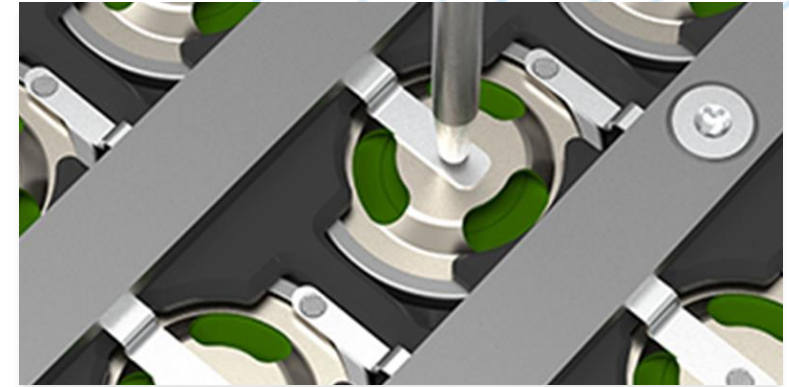

Battery / High Power Bonders





# ACCELONIX BV

Micro | Power Electronics Packaging Solutions

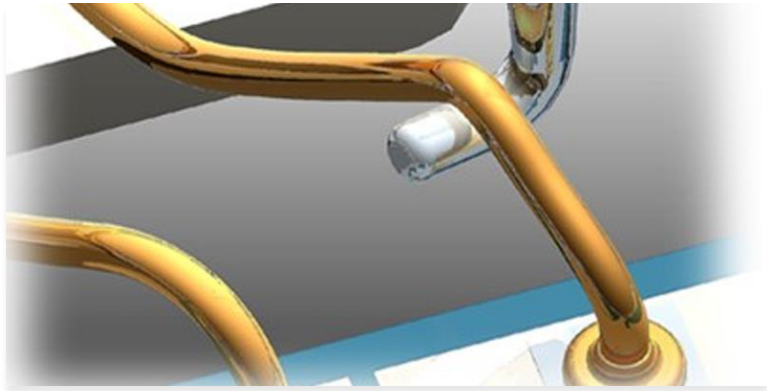

Bond Testing

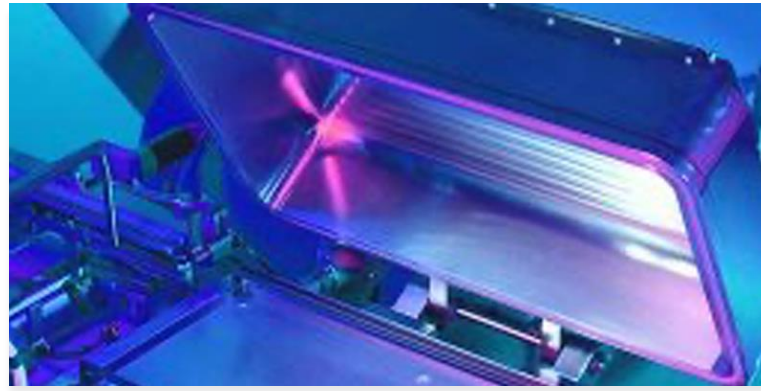

Plasma Cleaning

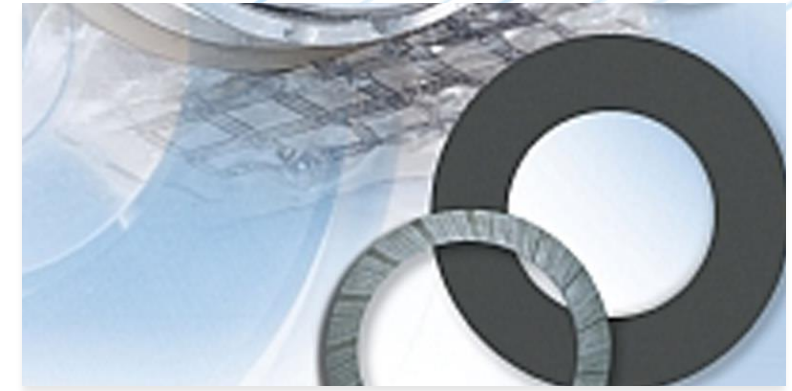

Consumables



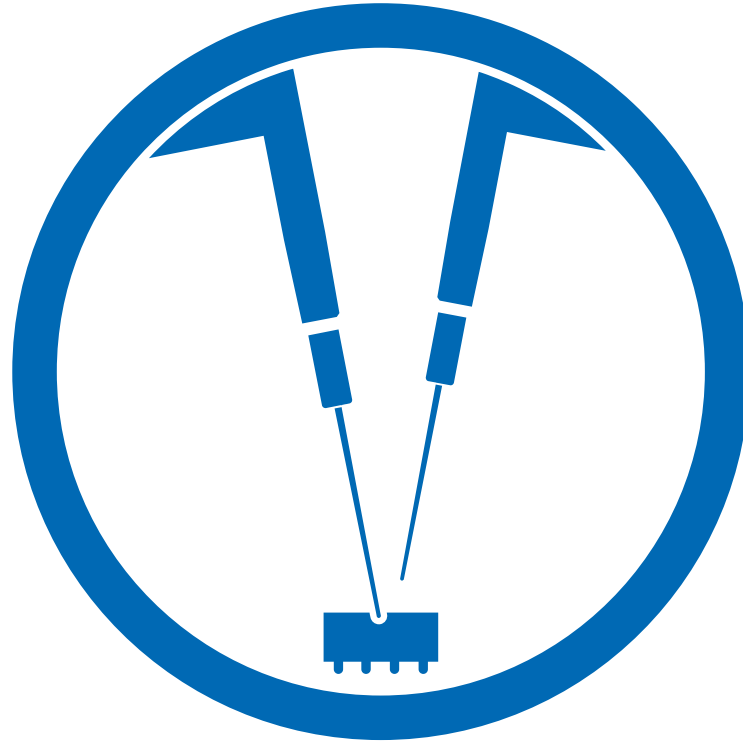

# **PCBA INSPECTION & TEST**



# ACCELONIX BV

## PCBA Test & Inspection Solutions



3D AOI & SPI



Embedded JTAG Bscan Test  
In-System Programming



Device Programming

CHECKSUM ✓

comet  
yxlon

GOPEL  
electronic  
Enjoy Testing

VCcount  
by VisiConsult

ASTER  
TECHNOLOGIES

Data iO

TAKAYA

Chroma  
Advancing Excellence

IET IET LABS, INC.  
in the GenRad Tradition

HUNTRON

Accelonix  
SOFTWARE



# ACCELONIX BV

## PCBA Test & Inspection Solutions



FA & Visual Inspection

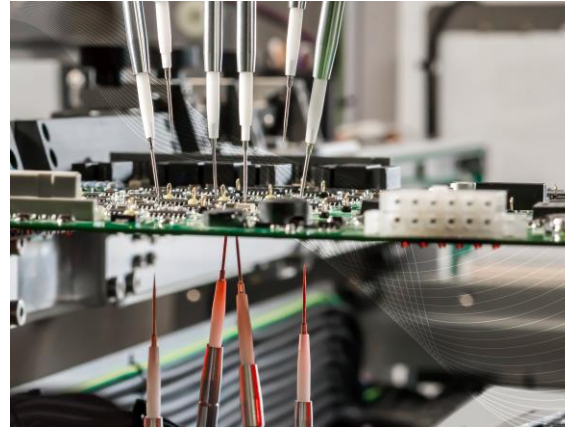

Flying Probe Test  
Standalone & Inline



DfT, DfM, Test Coverage, NPI,  
Repair & Traceability Software

CHECKSUM ✓

comet  
yxlon

GOPEL  
electronic  
Enjoy Testing

VCcount  
by VisiConsult

ASTER  
TECHNOLOGIES

Data iO

TAKAYA

Chroma  
Advancing Excellence

IET IET LABS, INC.  
in the GenRad Tradition

HUNTRON

Accelonix  
SOFTWARE

# ACCELONIX BV

## PCBA Test & Inspection Solutions

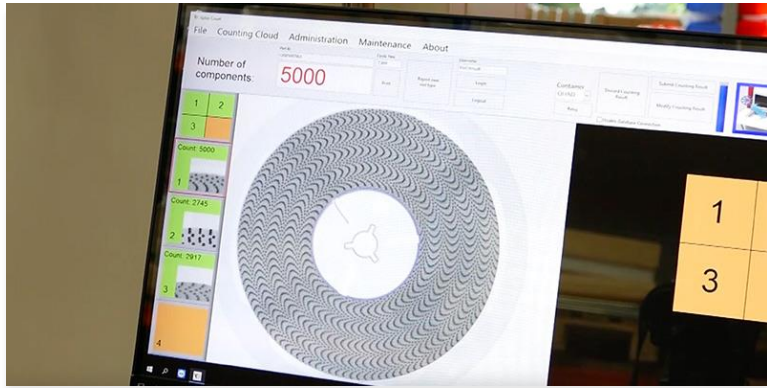

X-Ray Component Counting

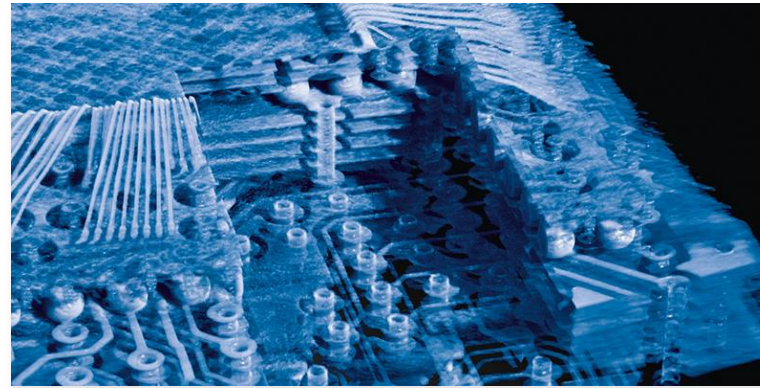

X-Ray Inspection  
Manual & Inline



Repair & Troubleshoot

CHECKSUM ✓

comet  
yxlon

GOPEL  
electronic  
Enjoy Testing

VCcount  
by VisiConsult

ASTER  
TECHNOLOGIES

Data iO

TAKAYA

Chroma  
Advancing Excellence

IET IET LABS, INC.  
in the GenRad Tradition

HUNTRON

Accelonix  
SOFTWARE

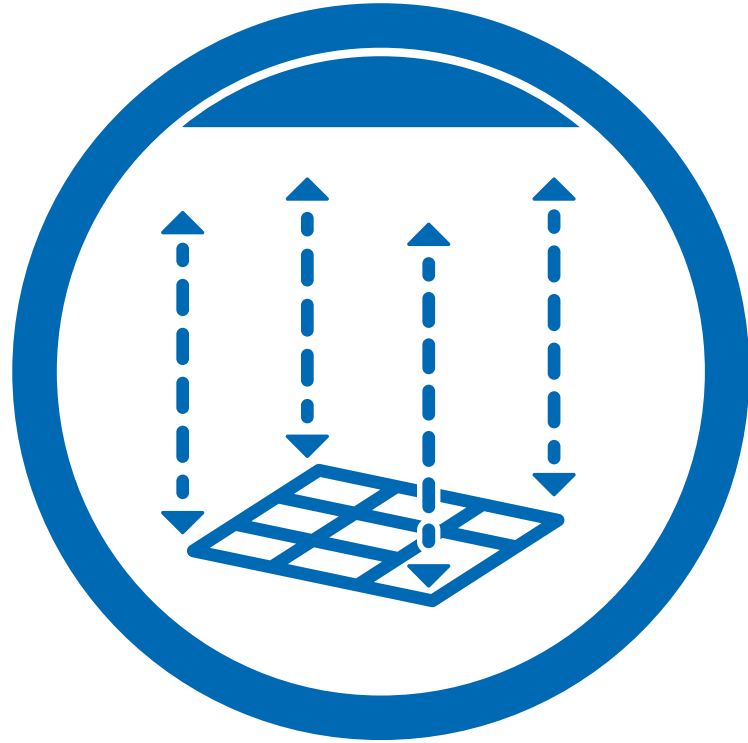

# **METROLOGY**





# ACCELONIX BV

## Metrology Solutions

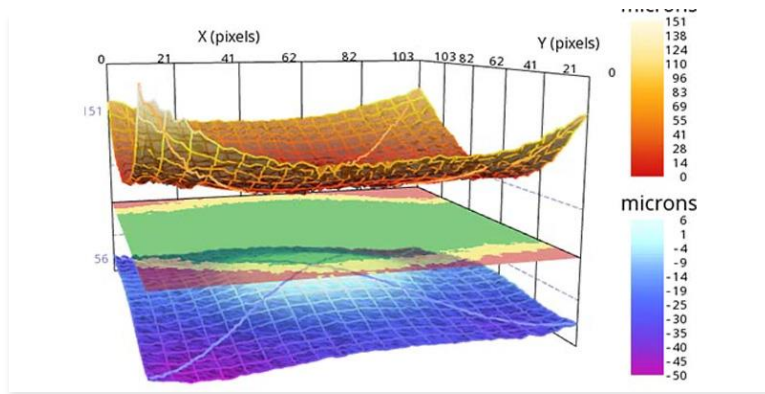

Thermal Warpage and Strain Metrology

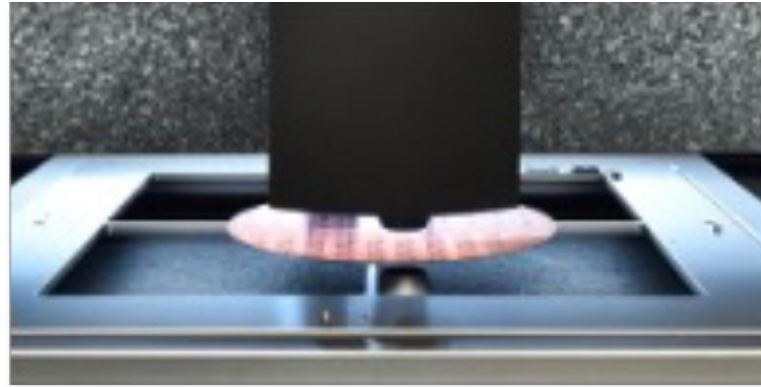

3D Non-Contact Surface Metrology

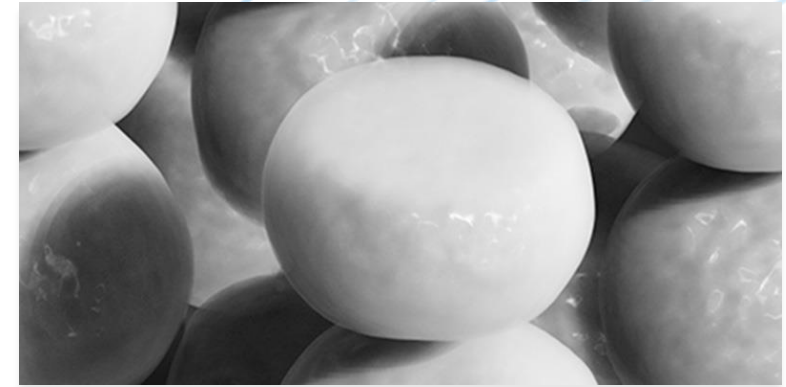

X-Ray and CT Metrology (Computed Tomography)





# **SERVICES AND SUPPORT**



# ACCELONIX BV

## Services and Support



Flying Probe  
Test Service

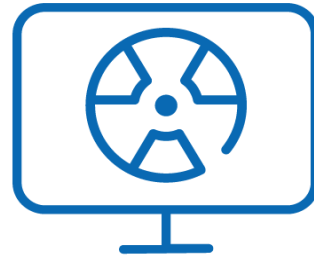

X-ray & CT  
Inspection

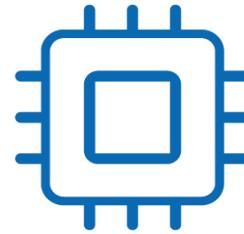

Micro Electronics  
Packaging



Equipment  
Rental

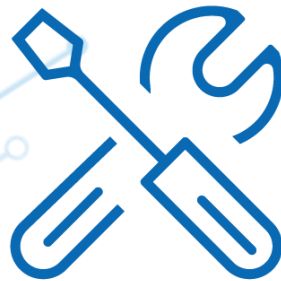

Repair &  
Calibration

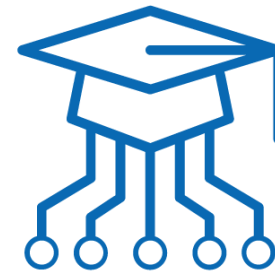

Training  
Consultancy







# ACCELONIX BV

## Support

### New Equipment

- Pre-installation Requirement
- Installation and Commissioning
- Training and Application Support

### Life Cycle Support

- Calibration and Preventive Maintenance
- Repair
- Support Contracts: including telephone, e-mail and swift on-site support
- Upgrades and Updates





# ACCELONIX BV

## Production Services

### Local based production services

- Wire Bonding and Die Bonding Prototyping
- Battery Bonding
- X-ray 2D, 2.5D & 3D Inspection Service
- Flying Probe Test and JTAG/Bscan Testing

### Rental

- EMC Generators, RF Amplifiers



# ACCELONIX BV

- Solution provider
- Cross-Sell Complementary products, creating bundled solutions to meet wider range of customer needs.
- Technical skilled and trained Sales and Service personal with many year experience operating in Electronics industry and local market expertise.
- Intensive customer contact
- Excellent after sales support and services
- Streamline communication between manufacturer and the target market.



# Accelonix Inspection Xpress

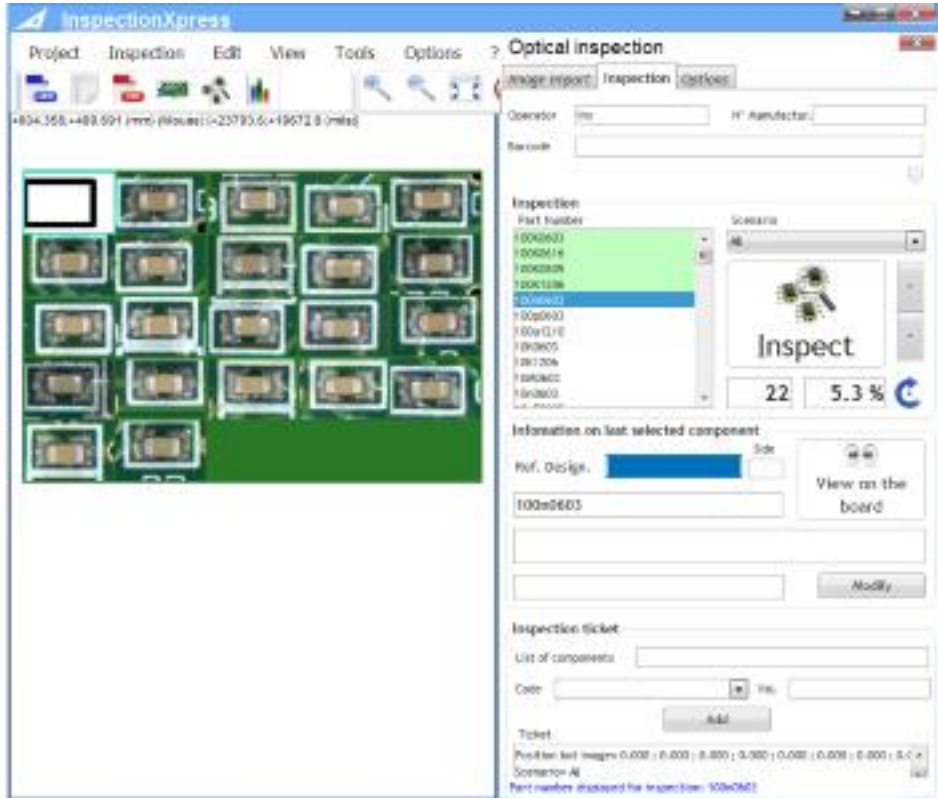

Inspection Xpress is a powerful solution for the visual inspection of first article, prototypes, small-series production, sampling and Final Inspection.

- Inspection Xpress Reduces Inspection Time
- Uses a Unique way to Display Components during Inspection
- Integrated scanner or external imaging system
- Works with almost all image formats
- Cost Effective



# Goepel Automated Optical Inspection

Inline and Standalone SPI and AOI Systems for 3D, 2D, and angled camera's.

Optimized Systems for THT Inspection.



- New 3D AOI module with real 3D measurement of solder joints and components without shadowing effects
- Stable inspection with almost zero false call and pseudo error rate.
- MagicClick automated inspection program generation in minutes
- High end camera modules including illumination from Infrared to Ultraviolet and 3D/2D Angled View Inspection over 360°
- PILOT AOI software with powerful functions for component recognition, solder joint and short inspection, OCR, color verification as well as solder paste inspection.

# X-Ray Inspection

**comet**  
yxlon

- Fast X-ray Inspection Solutions for 2D, 3D and laminography
- Easy and intuitive operation
- FeinFocus X-ray tube technology
- High Power Target technology
- Finely calibrated, long-life flat-panel detector
- Manipulator with cushioned bearings
- Variety of sample tables
- 2D, 2.5D and 3D images with extremely high resolution
- Accurate void detection, including multi area voiding
- Fast, automated, easy ADR routines
- Very fast live (on the fly) inspections
- CT and microCT module for in-depth 3D examination via virtual cross sections and layers
- QuickScan® module, for 3D images and virtual slices within a minute.

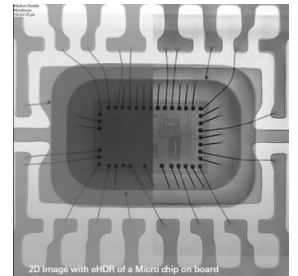
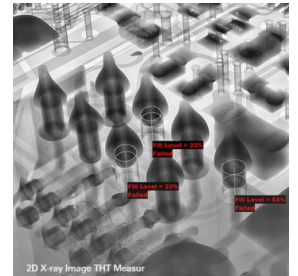
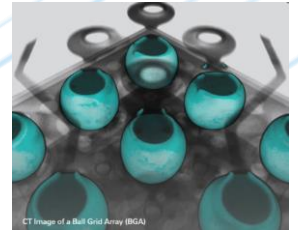



# Goepel Automated X-Ray (& AOI) Inspection

Inline AX(O)I System for 2D and 3D X-ray Inspection of (hidden) solder joints and components. Optional AOI integration.

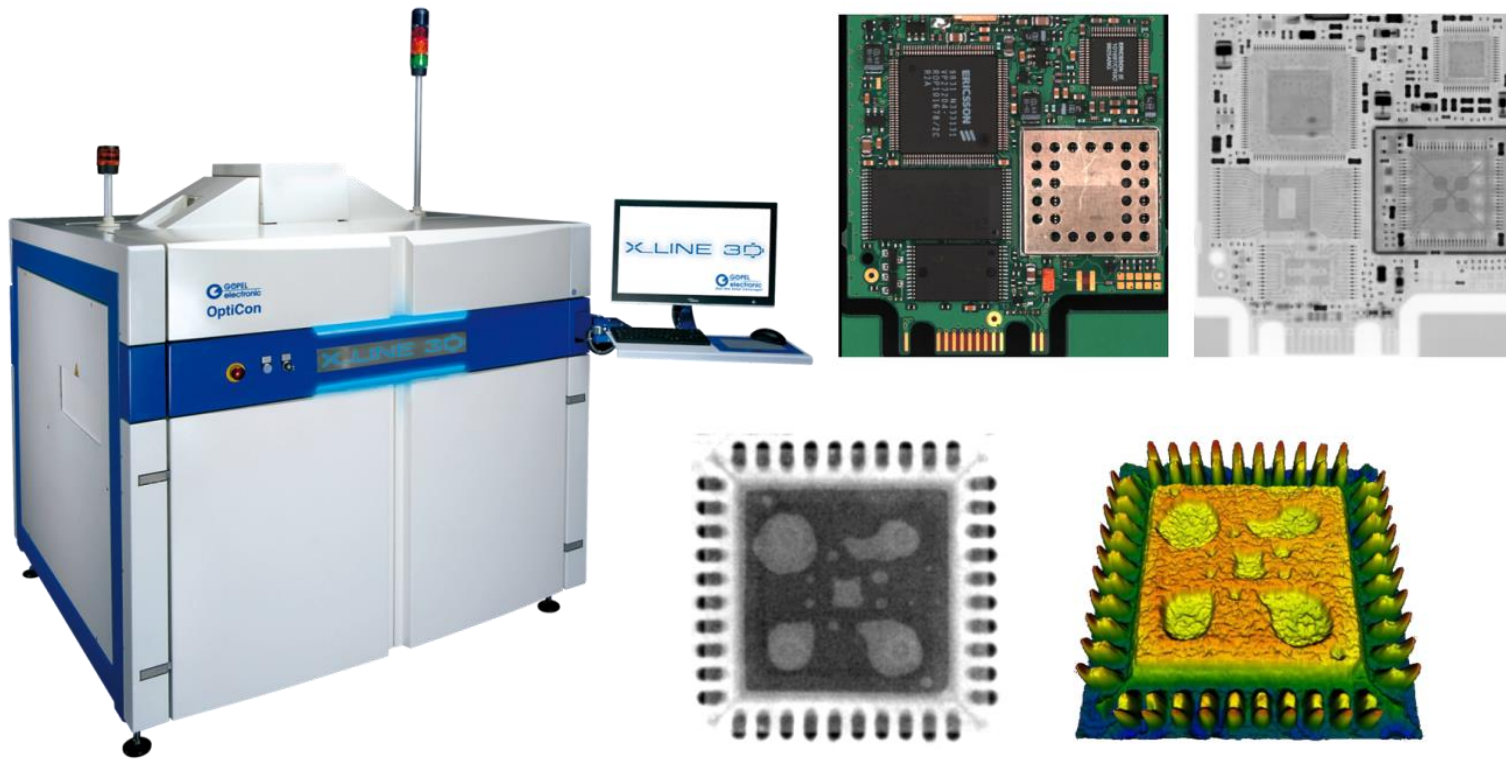

- Revolutionary GigaPixel technology with real-time multi angle image recording for fastest test speed at full 3D PCB capturing.
- Solder joints analysis on various levels and determine the wetting state.
- Reconstruction processes with tomosynthesis.
- Simultaneous inspection of top and bottom side of a double sided PCB.
- Reduced PCB handling time of 5 s
- Software XI-PILOT with Algorithm library suitable for all common components.
- Combination with AOI inspection module in 1 system.

# Takaya Flying Probe Test

New generation flying probe test system high test speed, positioning accuracy and test coverage. Facilitates testing for R&D prototypes and NPI up to low-volume productions.

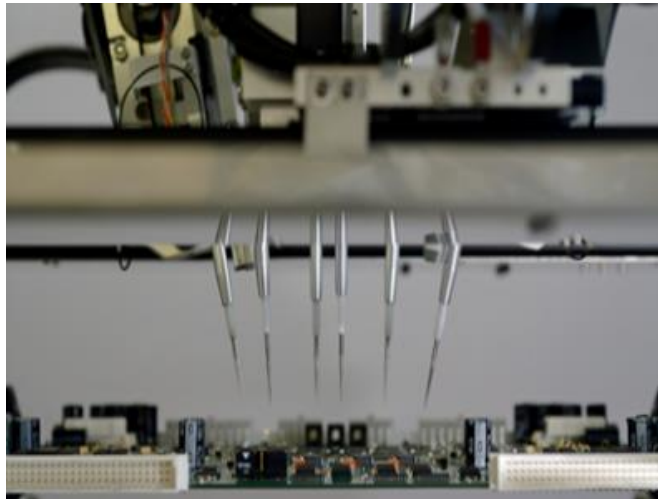

- Flying 4-Head and 6 Z-Mechanisms
- Highly Accurate Measurement System
- Strong and Rigid XY Stage
- Ultrafast Test Speed
- Color Camera System and Real Map Software
- Easy and User Friendly Software and Security Function
- Attenuating Contact Pressure of Probes
- Versatile Test Options, including Optical Test, Sensor test and more
- In-Line System

# Goepel JTAG/Boundary Scan

CASCON GALAXY Boundary scan test and programming suite.  
With unique JTAG/Boundary Scan programming language, extensive Library and Push button ATPG tool. Including Emulation Test (VarioTAP) en embedded instrumentation (ChipVorex).  
Features Automatic fault diagnosis on pin level.

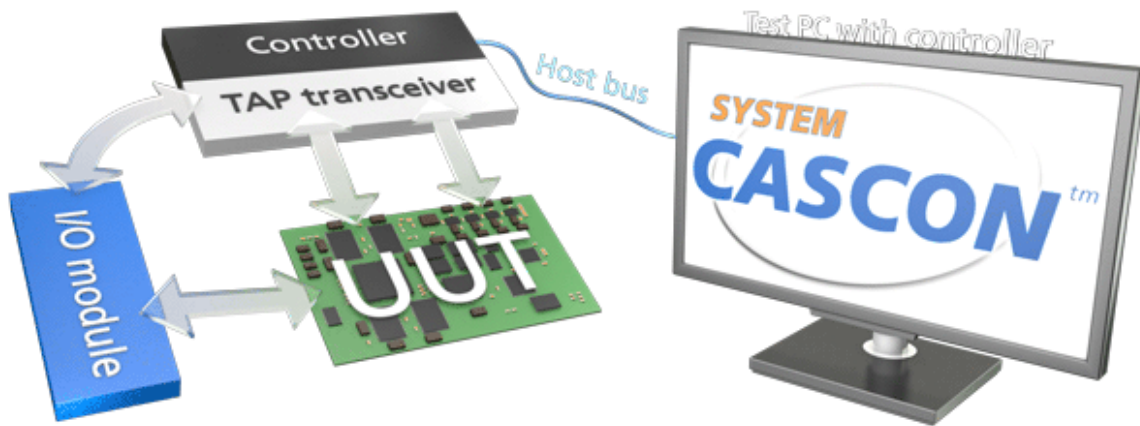

- Wide range of hardware controllers, TAP interfaces and I/O Modules
- Full software support by JTAG/Boundary Scan development environment SYSTEM CASCON
- Scalable TCK frequency up to 100MHz
- Applicable for Standard Boundary Scan test, in-system programming (ISP) and in-system configuration (ISC)
- Easy integration based on preconfigured plug-ins (NI LabView, TestStand, other ATE)
- Universal solutions for laboratory and production



FlashFOX

New generation stand-alone flash programmer for production

# Aster twExpress

Powerfull manufacturing engineering tools that combine early DFM and DFT with smart NPI tools, including testcoverage analysis.  
Based on production yield calculations it is possible to optimize and combine various types of inspection and test strategies within an integrated productionflow.

## Software solutions for PCB Assembly & Test supporting industry 4.0

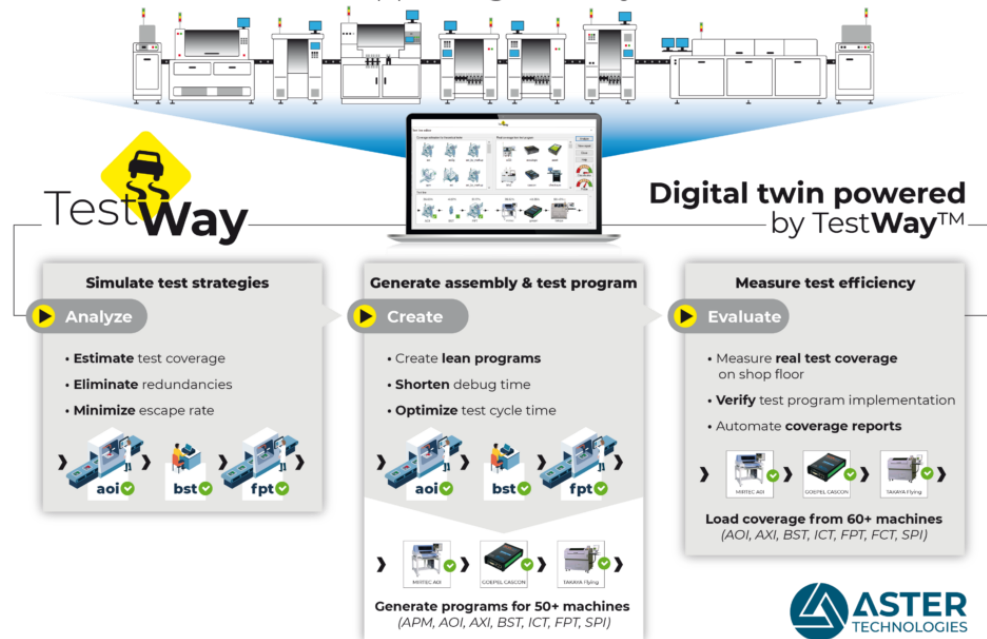

- Board, CAD & System visualization
- DfX rules checking
- Test coverage estimation & measurement
- Functional test coverage declaration
- Test Probe Analyzer & Test point saving
- Test and Assembly Machine Interfaces
- Shop floor documentation
- Advanced reporting
- Test Cost modeling
- Fault ticket viewer with Repair & Diagnostic aid

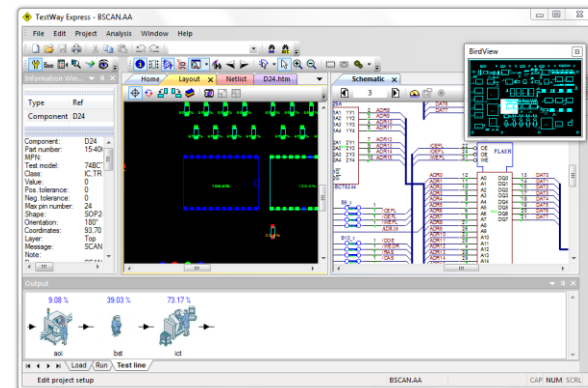



# Aster Quad

Flexible modular Quality Management system, providing traceability, for the PCB electronic production data.

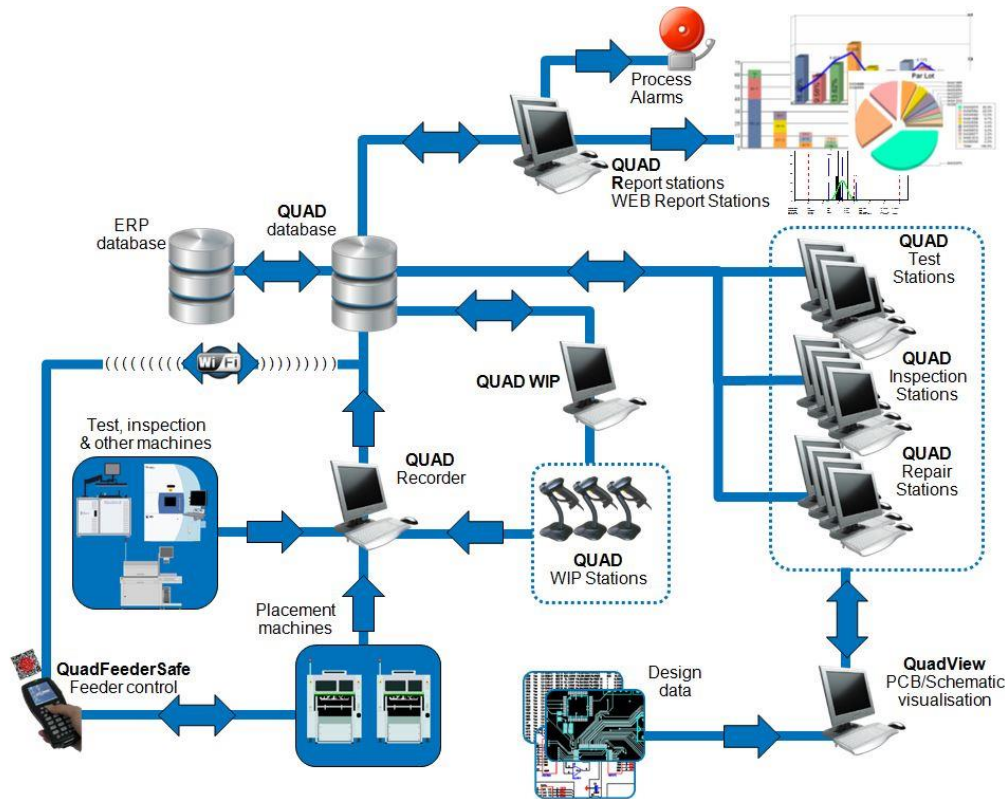

## QuadRecorder

automatically collect data from sources on your shop floor. Once the data is collected, the tools can be applied for paperless inspection, test, diagnosis and repair.

## QuadFeederSafe

for production component management, feeder management, loading management and component traceability.

## QuadWIP

for board or batch location and timing checks.

## QuadReports and QuadWebReports

for production and publication of real time reports and alarms.

## Quad-DPMO

extracts the true Defect Per Million Opportunities from the traceability database, built from the production line.



# Data I/O Device Programming



For nearly 40 years, Data I/O Corporation has been the world leader in the manufacture, distribution and service of innovative solutions for programmable devices.

- PSV-series: Fully automated programming
- FlashPAK: Versatile device programmer
- LumenX: Large density Flash, eMMC devices



Engineered for speed and accuracy, the  
PSV3500/5000/7000



# Huntron Repair and Troubleshoot

Power-off Diagnostic Tools for PCBA  
Troubleshooting.

- ASA technology
- Benchtop trackers
- Robotic Probers
- Workstation software
- Integrations

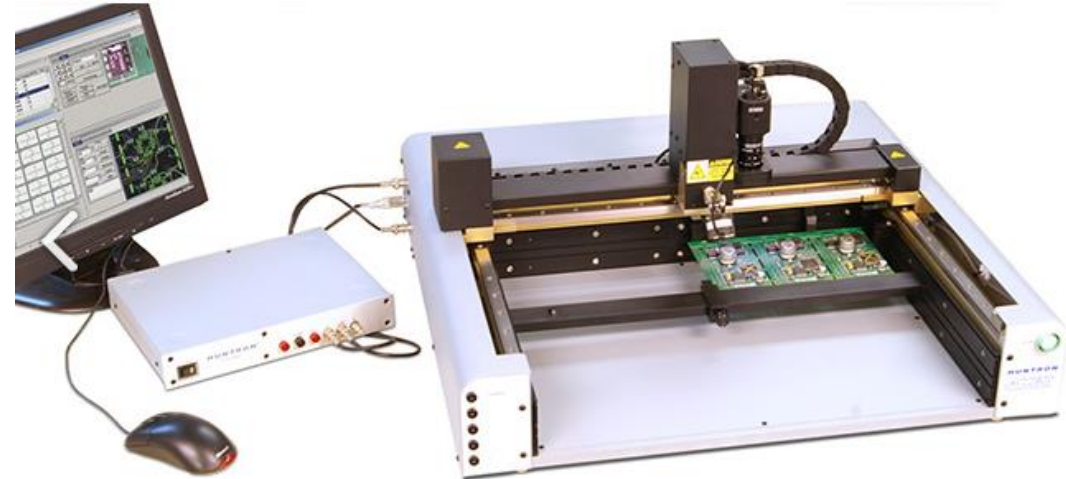
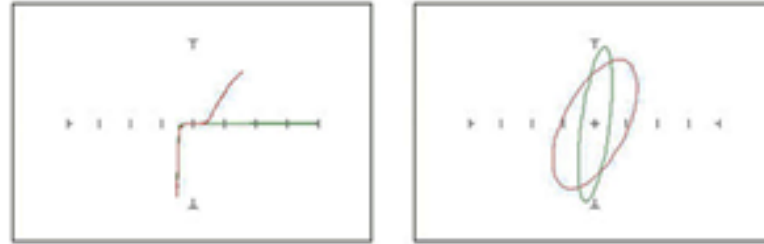

# XRH Count

## Component inventory counting

XRHCount is a compact X-ray unit to count all common and most special SMT component-types on reels with a diameter up to 400mm.

- Counting of components in Reels, Trays, Sticks, Bags
- Multiple Reel Counting
- Automatic barcode recognition
- Recognition of odd shapes
- Splicing Detection
- 8,5 sec. cycle time
- Statistic suite
- MES Connection

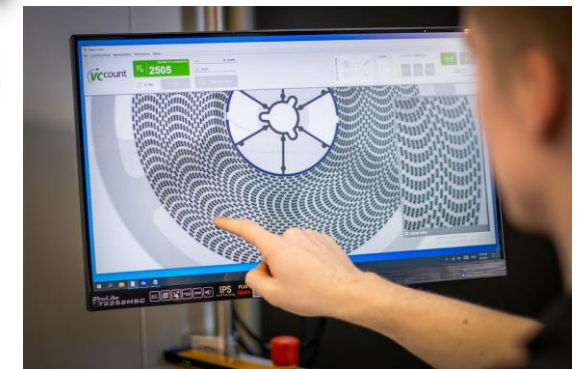
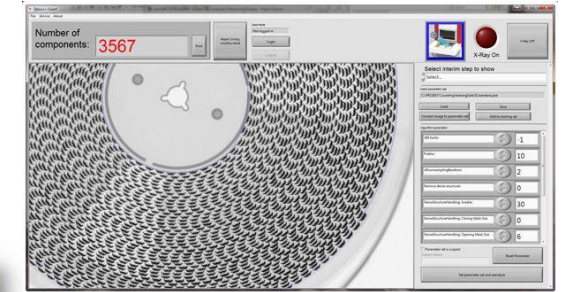



# Musashi Engineering Coating, Dispensing & Jetting Equipment



Dot dispensing



Line dispensing

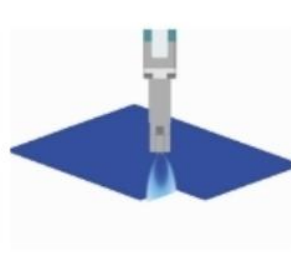

coating

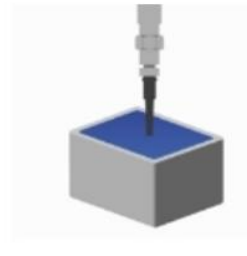

Filling



Desktop robots

High-Precision and High-Rigidity Gate Type Desktop Robot SHOTMASTERQX



Desktop robots

Desktop Robot with PC Controlled Image Recognition Function 350PCSmart SMQX



Fully automatic dispensing system

Full-automatic substrates FCD1200



Fully automatic dispensing system

Fully Automatic Substrate Coating Machine FCD1000



Musashi Engineering provides an abundant lineup of products including dispensing head controllers as a core of the dispensing system, desktop robots that control precision dispensing, fully automatic dispensing and coating devices, and parts such as nozzles and syringes.



**Accelonix BV • Luchthavenweg 18-b • Eindhoven • Netherlands**  
**T: +31 40 7501650 • E questions: sales@accelonix.nl • E orders: sales@accelonix.nl**

 [www.accelonix.nl](http://www.accelonix.nl)

 **Accelonix Benelux**

 **accelonixbnx BV**